

**TECHNICAL MANUAL
OPERATOR'S MANUAL**

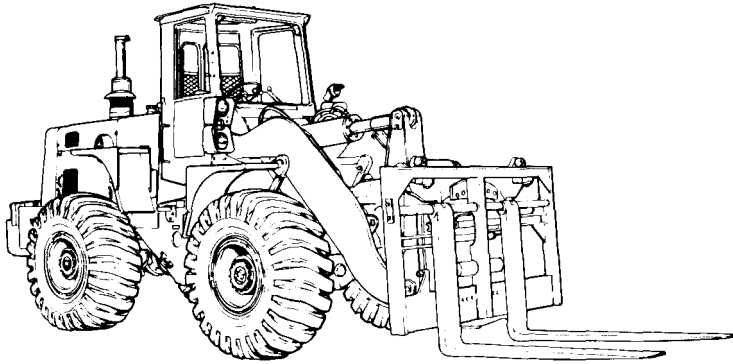

S/N 2000 AND BELOW

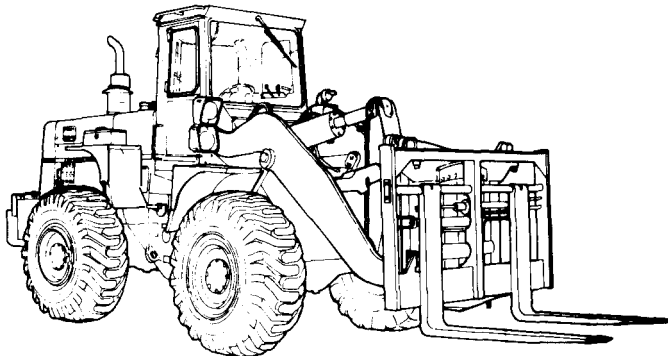

S/N 2001 AND ABOVE

**TRUCK, FORKLIFT, DED
PNEUMATIC TIRE,
10,000 LB. CAPACITY
ROUGH TERRAIN,
ARTICULATED FRAME STEER
(DRESSER INDUSTRIES
MODEL M10A, MHE 236)
(NSN 3930-01-054-3833)**

TABLE OF CONTENTS

Page i

EQUIPMENT
DESCRIPTION

Page 1-6

OPERATING
INSTRUCTIONS

Page 2-1

PREVENTIVE
MAINTENANCE

Page 2-14

LUBRICATION
INSTRUCTIONS

Page 3-1

TROUBLESHOOTING
PROCEDURES

Page 3-4

MAINTENANCE
PROCEDURES

Page 3-12

SUBJECT INDEX

Page Index-1

*This manual supersedes the Operator's portion of TM 10-3930-643-14&P, dated 30 Nov 81 with all changes

APPROVED FOR PUBLIC RELEASE. DISTRIBUTION IS UNLIMITED.

WARNING

ACCIDENTAL MOVEMENT

To prevent accidental movement of the forklift apply parking/emergency brake, place transmission directional lever in neutral position and lock, before starting engine.

WARNING

ARTICULATION HAZARD

Before checking transmission oil level, make sure that the frame locking bar is pinned securely to prevent articulation.

WARNING

BURN HAZARD

Allow engine to cool before performing maintenance on the muffler, exhaust pipe, exhaust manifold or turbo-charger. If necessary, use insulated pad or gloves. Failure to follow this procedure could cause SEVERE INJURY .

WARNING

CHEMICAL BURN HAZARD

Sulfuric acid contained in batteries can cause severe chemical burns. Wear protective goggles and gloves when working with batteries. Avoid contact with eyes, skin or clothing. If the electrolyte is spilled, take immediate action to stop its burning effects:

EYES :	Flush with cold water for 15 minutes. Seek medical attention immediately.
INTERNAL:	Drink large amounts of water or milk. Follow with milk of magnesia, beaten egg, or vegetable oil. Seek medical attention immediately.
EXTERNAL:	Flush with cold water until all acid has been removed.
CLOTHING OR VEHICLE:	Wash with cold water at once. Neutralize acid with baking soda or household ammonia solution.

WARNING

COMPRESSED AIR HAZARD

Compressed air used for cleaning purposes will not exceed 30 psi. Use only with effective chip guarding and personal protective equipment (goggles/shield, gloves, etc.).

WARNING

EMERGENCY BRAKING

If emergency brake must be used to stop forklift, prepare for sudden stop and brace yourself to prevent serious head, neck and back injuries.

WARNING

EXHAUST GASES CAN BE DEADLY

Exhaust gases can produce symptoms of headache, dizziness and loss of muscular control. DEATH, coma or permanent brain damage can result from severe exposure. You can insure your safety by following these rules:

- . Do not operate the heater or engine in enclosed areas unless the area is properly ventilated.
- If you notice exhaust odors or exposure systems, IMMEDIATELY VENTILATE the area.
- Remove affected personnel and take the following actions:
 - Expose affected personnel to fresh air.
 - If necessary, administer artificial respiration.
 - Keep affected personnel warm.
 - Do not permit physical exertion.
 - Seek medical attention immediately.

Refer to FM 21-11, First Aid for Soldiers, for first aid treatment of injured personnel.

WARNING

MAINTENANCE PERSONNEL SAFETY

Unless otherwise specified, perform all maintenance procedures with all equipment lowered to the ground, transmission in neutral, parking/emergency brake applied and the engine stopped.

WARNING

FIRE HAZARD

Diesel fuel and combustible materials are used in the operation and maintenance of this equipment. Do not smoke or allow open flames or sparks in areas where diesel fuel or combustible materials are used or stored. Failure to follow this procedure could cause DEATH or SERIOUS INJURY.

WARNING

FLAMMABLE

Battery gases are flammable and can explode. Do not smoke or allow open flames or sparks near batteries. Failure to follow this procedure could result in DEATH or SERIOUS INJURY.

WARNING

LOSS OF CONTROL

When traveling downhill, never shift transmission into neutral. You could lose control of the forklift and be seriously injured.

WARNING

LOSS OF STEERING

Be sure that the frame locking bar is removed before operating vehicle. Failure to do so will cause loss of steering control, which may result in DEATH or SERIOUS INJURY .

WARNING

NOISE HAZARD

Noise level exceeds 85 dB(A) at three feet in front, 15 feet to the side and 24 feet to the rear of the vehicle. All personnel will wear hearing protection when operating or performing maintenance on the vehicle. Failure to follow this procedure could cause serious hearing damage.

WARNING

OPERATOR SAFETY

Before starting engine and operating forklift be thoroughly familiar with the information in this manual. Also review all warnings and safety precautions.

WARNING

OVERLOAD

Do not overload. Do not tilt load beyond vertical position on mast when elevated, unless load is over a stack. Failure to follow this procedure could result in DEATH or SERIOUS INJURY.

WARNING

PERSONAL SAFETY HAZARD

Stay clear of any and all moving parts of the forklift when boom and forks are not lowered to the ground. Use extreme caution to prevent SERIOUS INJURY while performing maintenance.

WARNING

USE SAFETY BELTS

Be sure your seat belt is fastened before starting engine and operating the vehicle. Avoid sudden stops and operate at a safe speed.

WARNING

STEAM HAZARD

When engine is hot, remove radiator cap slowly to relieve pressure. Use gloves and protective clothing to prevent scalding by steam or contact with hot metal. Failure to follow these instructions could result in SEVERE INJURY. If injured seek medical attention immediately.

WARNING

TOXIC/FLAMMABLE

Dry cleaning solvent (P-D-680), used for cleaning parts is toxic and flammable. Use only in well ventilated areas. Wear protective goggles and gloves. Do not smoke or allow open flames or sparks in areas where cleaning solvent is used or stored. Avoid contact with eyes, skin or clothing. If contact with eyes is made, flush with cold water and seek medical attention immediately. If contact with skin or clothing is made, flush with cold water. If you become dizzy while using cleaning solvent, get fresh air immediately.

WARNING

TOXIC/FLAMMABLE

Ether is toxic and flammable. Use only in well ventilated areas. Avoid contact with eyes, skin and clothes. Do not use ether or discard ether container near an open flame, sparks or heat. Failure to follow these instructions could result in SEVERE INJURY. If injured, seek medical attention immediately.

OPERATOR'S MANUAL

TRUCK, FORKLIFT, DED, PNEUMATIC TIRE, 10,000 LB.
 CAPACITY, ROUGH TERRAIN, ARTICULATED FRAME STEER,
 DRESSER INDUSTRIES MODEL M10A, MHE MODEL 236,
 (NSN 3930-01-054-3833)

REPORTING ERRORS AND RECOMMENDING IMPROVEMENTS

You can help improve this manual. If you find any mistakes or if you know of a way to improve the procedures, please let us know. Mail your letter, DA Form 2028 (Recommended Changes to Publication and Blank Forms), or DA Form 2028-2 located in the back of this manual directly to: Commander, U.S. Army Tank-Automotive Command, ATTN: AMSTA-MB, Warren, MI 48397-5000. A reply will be furnished to you.

TABLE OF CONTENTS

		<u>Paragraph</u>	<u>Page</u>
CHAPTER 1.	INTRODUCTION		
	CHAPTER OVERVIEW		1-1
	HOW TO USE THIS MANUAL		1-1
	INDEX		1-1
Section I	GENERAL INFORMATION		
	Scope	1-1	1-3
	Maintenance Forms and Records	1-2	1-3
	Reporting Equipment Improvement Recommendations	1-3	1-3
	Hand Receipt	1-4	1-3
	Warranty Information	1-5	1-4
	Serial Number Location	1-6	1-4
	List of Abbreviations	1-7	1-5
Section II	EQUIPMENT DESCRIPTION AND DATA		
	Equipment Characteristics, Capabilities and Features	1-8	1-6
	Location and Description of Major Components	1-9	1-7
	Differences Between Models	1-10	1-8
	Equipment Data	1-11	1-13
Section III	PRINCIPLES OF OPERATION		
	Engine	1-12	1-14
	Fuel System	1-13	1-14
	Exhaust System	1-14	1-15
	Cooling System	1-15	1-15
	Electrical System	1-16	1-16
	Transmission Controls	1-17	1-19
	Air System	1-18	1-20
	Brakes	1-19	1-21
	Steering	1-20	1-22
	Hydraulic System and Implements	1-21	1-22

APPROVED FOR PUBLIC RELEASE. DISTRIBUTION IS UNLIMITED.

* This manual supersedes the Operator's portion of TM 10-3930-643-14&P, dated 30 Nov 81 with all changes.

TABLE OF CONTENTS-Continued

		<u>Paragraph</u>	<u>Page</u>
CHAPTER 2.	<u>OPERATING INSTRUCTIONS~</u>		2-1
	CHAPTER OVERVIEW		2-1
	INDEX		2-1
Section I	DESCRIPTION AND USE OF OPERATOR'S CONTROLS AND INDICATORS		
	Operator's Compartment	2-1	2-3
	Instrument Console	2-2	2-4
	Steering Wheel and Hand Throttle Control	2-3	2-8
	Service Brakes, Brake and Transmission Disconnect Pedal and Accelerator	2-4	2-9
	Transmission Gear Range Lever, Transmission Direction Lever, and Transmission Safety Lock	2-5	2-9
	Lift Control Lever, Tilt Control Lever, and Fork Control Lock	2-6	2-10
	Sideshift, Oscillate, and Fork Positioner Lever	2-7	2-10
	Mode Selector Switch	2-8	2-11
	Windows	2-9	2-11
	Heater Controls	2-10	2-12
	Defroster Fan Speed Switches	2-11	2-12
	Windshield Wiper Controls	2-12	2-12
	Rear Window Wiper Controls	2-13	2-12
	Air Cleaner Service Indicator	2-14	2-13
	Electrical System Master Disconnect Switch	2-15	2-13
	Coolant Level Sight Gage	2-16	2-13
	Engine Oil Dipstick	2-17	2-13
Section II	<u>PREVENTIVE MAINTENANCE CHECKS AND SERVICES</u>		
	Preventive Maintenance Checks and Services	2-18	2-14
Section III	OPERATION UNDER USUAL CONDITIONS		
	Initial Adjustments, Daily Checks, and Self Test	2-19	2-31
	Operating Procedures	2-20	2-32
	Preparation For Movement	2-21	2-44
	Operating Instructions on Decals and Instruction Plates	2-22	2-45
Section IV	OPERATION UNDER UNUSUAL CONDITIONS		
	Operation in Unusual Weather	2-23	2-54
	Operation in Dusty or Sandy Areas	2-24	2-57
	Operation in Saltwater Areas	2-25	2-57
	Operation in High Altitudes	2-26	2-57
	Operation in Snow	2-27	2-57
	Fording	2-28	2-57

TABLES OF CONTENTS-Continued

		<u>Paragraph</u>	<u>Page</u>
CHAPTER 3.	OPERATOR/CREW MAINTENANCE INSTRUCTIONS		3-1
	CHAPTER OVERVIEW		3-1
	INDEX		3-1
Section I	<u>LUBRICATION</u>		
	Lubrication Instructions	3-1	3-1
	Lubrication Information	3-2	3-2
Section II	<u>OPERATOR/CREW TROUBLESHOOTING PROCEDURES</u>		
	Troubleshooting Information	3-3	3-2
	Troubleshooting Symptom Index	3-4	3-3
	Troubleshooting Procedures	3-5	3-4
Section III	<u>MAINTENANCE PROCEDURES</u>		
	Operator Maintenance	3-6	3-12
APPENDIX A	REFERENCES		A-1
APPENDIX B	COMPONENTS OF END ITEM LIST AND BASIC ISSUE ITEMS LIST		B-1
APPENDIX C	ADDITIONAL AUTHORIZATION LIST		C-1
APPENDIX D	EXPENDABLE/DURABLE SUPPLIES AND MATERIALS LIST		D-1
	<u>SUBJECT INDEX</u>		INDEX 1
	ERROR REPORTING FORM (DA-2028-2)		
	METRIC CONVERSION TABLE		

MHE 236 FORKLIFT TRUCK

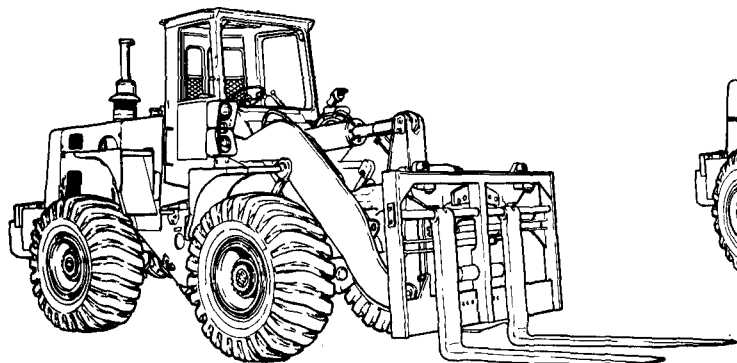

(Right Front View (S/N 2000 and below))

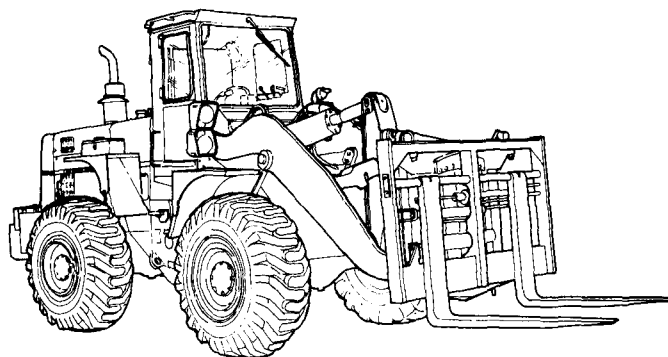

(Right Front View (S/N 2001 and above))

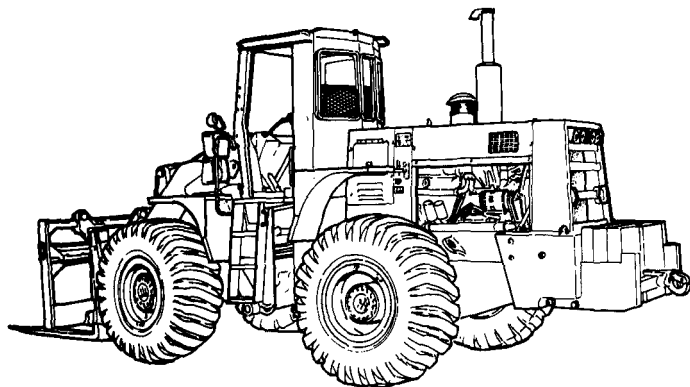

(Left Rear View (S/N 2000 and below))

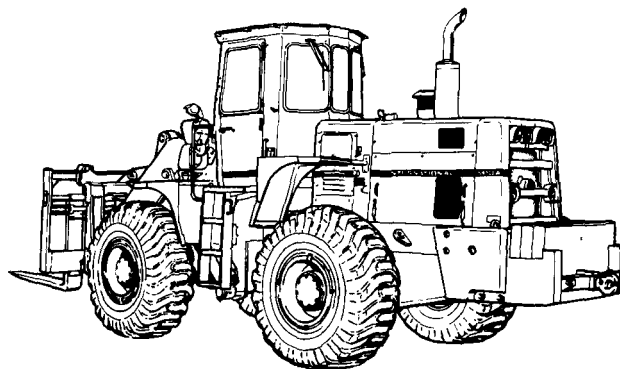

(Left Rear View (S/N 2001 and above))

TA327892

CHAPTER 1

INTRODUCTION

CHAPTER OVERVIEW

The purpose of this chapter is to acquaint you with the maintenance forms, records, and reports that you must maintain for the forklift truck, to familiarize you with the purpose and capabilities of the forklift truck and to give you a brief description of the different systems and components of the forklift truck.

HOW TO USE THIS MANUAL

This manual is designed to help you operate and maintain the M10A Forklift. It is divided into chapters, sections, and appendices. Chapter 1 contains information concerning the vehicle, its characteristics, systems, and components. Chapter 2 contains operating instructions, preventive maintenance information, and instructions for operation under unusual conditions. Chapter 3 contains procedures necessary for troubleshooting, maintenance, and general upkeep. The appendices contain supplemental information which you need to assist in the performance of the maintenance procedures.

In addition to the text, you will have either an assembled view or an exploded view illustration of the associated parts. The illustration is keyed to the text by numbers and shows you where an item is located on the vehicle. The text will tell you how an item functions or how to take a part off and put it on. The right side or left side of the forklift is defined as the right side or left side according to the operator seated in the operator's compartment.

INDEX

<u>Section</u>	<u>Title</u>	<u>Paragraph</u>	<u>Page</u>
I	GENERAL INFORMATION		
	Scope	1-1	1-3
	Maintenance Forms and Records	1-2	1-3
	Reporting Equipment Improvement		
	Recommendations	1-3	1-3
	Hand Receipts	1-4	1-3
	Warranty Information	1-5	1-4
	Serial Number Location	1-6	1-4
	List of Abbreviations	1-7	1-5
II	EQUIPMENT DESCRIPTION AND DATA		
	Equipment Characteristics, Capabilities, and Features	1-8	1-6
	Location and Description of Major Components	1-9	1-7
	Differences Between Models	1-10	1-8
	Equipment Data	1-11	1-13

INDEX-Continued

III	PRINCIPLES OF OPERATION		
	Engine	1-12	1-14
	Fuel System	1-13	1-14
	Exhaust System	1-14	1-15
	Cooling System	1-15	1-15
	Electrical System	1-16	1-16
	Transmission Controls	1-17	1-19
	Air System	1-18	1-20
	Brakes	1-19	1-21
	Steering	1-20	1-22
	Hydraulic System and Implements	1-21	1-22

Section 1. GENERAL INFORMATION

1-1. SCOPE. This manual presents the information you need for safe, efficient operation of the forklift, including authorized operating procedures, preventive maintenance, and service.

a. Type of Manual. Operator's Technical Manual includes operational troubleshooting and maintenance procedures.

NOTE

Storage container on left side of operator's compartment behind seat holds the Operator's Manual. This manual remains with the vehicle at all times.

b. Model Number and Equipment Name. MHE 236, (NSN 3930-01-054-3833) Rough Terrain 10,000 Pound Capacity, Articulated Frame Steer, Pneumatic Tire, DED, M10A Forklift Truck.

c. Purpose of Equipment. Handle, transport, and stock materials on various types of terrain. The Forklift truck has a capacity of 10,000 pounds at 48-inch load center and can lift the load to a maximum height of 121.6 inches.

d. Metric Dimensions. The equipment described herein is non metric and does not require metric common or special tools. Therefore, metric units are not supplied. Tactical instructions for sake of clarity will also remain non-metric.

1-2. MAINTENANCE FORMS AND RECORDS. Department of the Army forms and procedures used for equipment maintenance will be those prescribed by DA PAM 738-750, The Army Maintenance Management System (TAMMS).

1-3. REPORTING EQUIPMENT IMPROVEMENT RECOMMENDATIONS (EIR). If your M10A Forklift needs improvement, let us know. Send an EIR. You, the user, are the only one who can tell us what you don't like about your equipment. Let us know why you don't like the design. Put it on a SF 368 Quality Deficiency Report (QDR). EIR's should be mailed direct to: Commander, U. S. Army Tank Automotive Command, ATTN: AMSTA-QRT, Warren, MI 48397-5000.

A reply will be furnished directly to you.

1-4. HAND RECEIPT. This Operator's Manual has a companion document with a TM number followed by -HR (which stands for Hand Receipt). The TM 10-3930-643-12-HR consists of preprinted hand receipts (DA Form 2062) that list end item related equipment (i.e. COEI, BII, and AAL) you must account for. As an aid to property accountability, additional -HR manuals may be requisitioned from the following source in accordance with procedures in Chapter 3, AR 310-2:

The US Army Adjutant General Publications Center
Attn: AGLD-OD
1655 Woodson Road
St. Louis, MO. 63114

1-5. WARRANTY INFORMATION. The model MHE 236 forklift truck is warranted by Dresser Industries for 15 months or 1500 operating hours, whichever comes first.

The warranty starts on the date found on the DA Form 2408-9 in the log book. Report all defects in material or workmanship to your supervisor, who will take appropriate action through your organizational maintenance shop.

1-6. SERIAL NUMBER LOCATION. The serial number of the M10A forklift is located on the right side of the vehicle on the rear frame just forward of the rear wheel.

1-7. LIST OF ABBREVIATIONS.

A	After
AAL	Additional Authorization List
B	Before
BII	Basic Issue Items
B.O.	Blackout
CCE	Commercial Construction Equipment
COEI	Components of End Item
D	During
DA	Department of Army
D.C.	District of Columbia
DED	Diesel Engine Driven
EIR	Equipment Improvement Recommendations
F	Full
°F	Degrees Fahrenheit
FSCM	Federal Supply Code for Manufacturer
Gal	Gallons
H	High
ICOEI	Integral Components of End Item
In.	Inch
Kg	Kilogram
L	Low
LB	Pounds
LH	Left Hand
M	Medium
MHE	Material Handling Equipment
Mph	Miles per hour
N	Neutral
No.	Number
NSN	National Stock Number
PMCS	Preventive Maintenance Checks and Services
PSI	Pounds per square inch
Qty	Quantity
R	Reverse
RH	Right Hand
Rec'd	Received
Rpm	Revolutions per minute
SER.	Service
S/N	Serial Number
TAMMS	The Army Maintenance Management System
U/M	Unit of measure

Section II. EQUIPMENT DESCRIPTION AND DATA

1-8. EQUIPMENT CHARACTERISTICS, CAPABILITIES, AND FEATURES

a. Characteristics.

- Single diesel engine driven (turbocharged), Model DT-466B
- ROPS equipped
- Articulated frame steering
- Closed cab with environmental control (S/N 2001 and above)
- Full power shift transmission
- Boom-type fork arrangement (S/N 2001 and above)

b. Capabilities and features.

- . 10,000 pounds load capacity
- . 121.6 inch lifting height (maximum)
- . Operates over rough terrain
- Three speed ranges in both forward and reverse
- Brake and transmission disconnect pedal to neutralize transmission
- Power steering
- Power assisted brakes
- Oil sampling system (transmission and engine) (S/N 2001 and above)
- . Forks can be rotated and/or shifted left or right
- . Forks can be spread or closed hydraulically
- Forks can be tilted rearward or forward

1-9. LOCATION AND DESCRIPTION OF MAJOR COMPONENTS.

Legend

- | | |
|-------------------|--------------------------|
| 1. Engine | 5. Electrical system |
| 2. Fuel system | 6. Steering system |
| 3. Exhaust system | 7. Hydraulic lift system |
| 4. Cooling system | 8. Hydraulic reservoir |

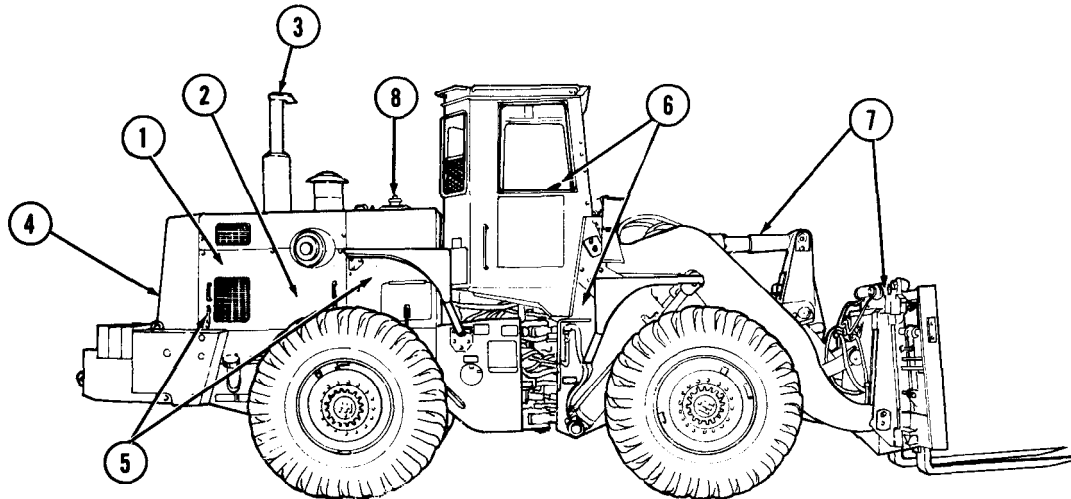

TA327893

- a. Engine (1). Six cylinder diesel.
- b. Fuel System (2). Consists of air cleaner, fuel tank, fuel filters, quick start kit, fuel injection pump, and fuel injectors. Vehicles with S/N 2001 and up, have a water separator on the bottom of the primary fuel filter.
- c. Exhaust System (3). Consists of muffler and exhaust pipe; muffler is mounted on top of engine, and is of the spark arresting type. S/N 2000 and below has a rain cap on the exhaust pipe.
- d. Cooling System (4). Includes radiator mounted in rear of truck, thermostat and housing, engine-driven water pump, and fan.
- e. Electrical System (5). 24 volt, negative ground. Includes engine-driven alternator, starter motor, instrument panel, light system, and two 12-volt batteries connected in series.
- f. Steering System (6). Consists of steering wheel, steering gear, two steering cylinders, torque converter-driven steering pump and a ground driven steering pump (which operates in event of engine failure).
- g. Hydraulic Lift System (7). Includes control valve, boom assembly, hydraulic reservoir, and cylinders (tilt, lift, rotation, sideshift, and fork position).
- h. Hydraulic Reservoir (8). Consists of tank for hydraulic fluid and relief valve.

1-9. LOCATION AND DESCRIPTION OF MAJOR COMPONENTS. -Continued

Legend

- 1. Transmission and drive shaft
- 2. Axles and tires
- 3. Brakes
- 4. Body and towing attachment

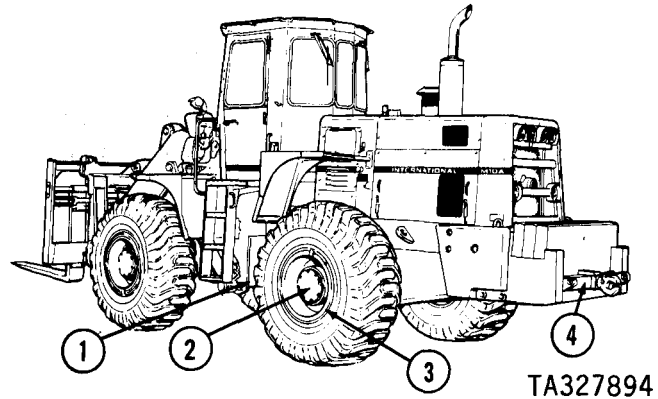

i. Transmission and Drive Shafts (1). Three speeds in both forward and reverse, has transmission disconnect feature which permits neutralizing transmission. Four drive shafts are used to transmit power to front and rear axles.

j. Axles and Tires (2). Single reduction type axles; pneumatic tires.

k. Brakes (3). Service brakes are air over hydraulic caliper-type disc brakes. The parking brake is a spring actuated, air pressure released, shoe-type brake, mounted on the rear drive line.

l. Body and Towing Attachments (4). Two section body consisting of front and rear chassis; towing attachments include pintle hook and tow bar located at rear of truck (S/N 2001 and above).

1-10. DIFFERENCES BETWEEN MODELS. Two models of the M10A are covered in this manual. The difference is noted by serial number. One is indicated as S/N 2000 and below, the other as S/N 2001 and above. The following chart lists the main differences.

COMPONENTS	2000 and below	2001 and above
A Rollover Protective Structure	X	
B Cab, Rollover Protective Structure		X
C Backup Alarm		X
D Engine Oil Sample Valve		X
E Transmission Oil Sample Valve		X
F Boom Prop		X
G Heater		X
H Defroster		X
I Wipers		X
J Fuel and Water Separator Filter		X
K Service Brake Pressure Converter Warning Signal		X
L Tool Box		X
M Key Operated Master Disconnect and Ignition Switches	X	
N Rain Cap on Exhaust Pipe	X	
O Key Not Required For Master Disconnect and Ignition Switches		X

1-10 DIFFERENCE BETWEEN MODELS.-Continued

SERIAL NUMBER 2000 AND BELOW

A Rollover Protective Structure. This provides operator protection in the event of machine rollover or upset.

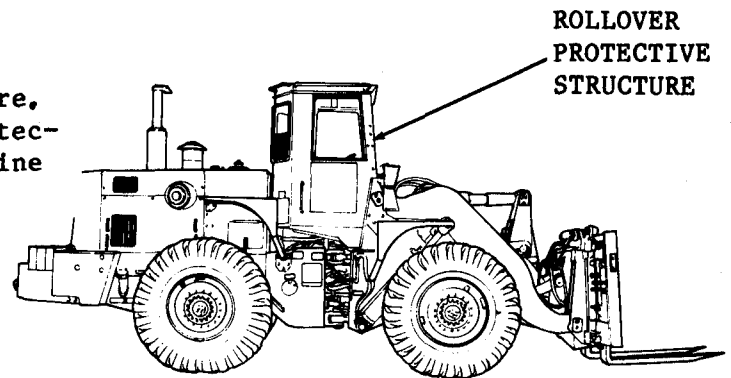

SERIAL NUMBER 2001 AND UP

B Cab, ROPS. This provides operator comfort in inclement weather, and also operator protection in the event of machine rollover or upset.

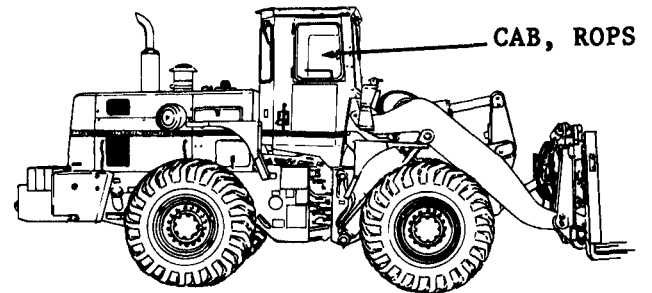

C Backup alarm. A safety feature to notify any one behind the machine to clear the area.

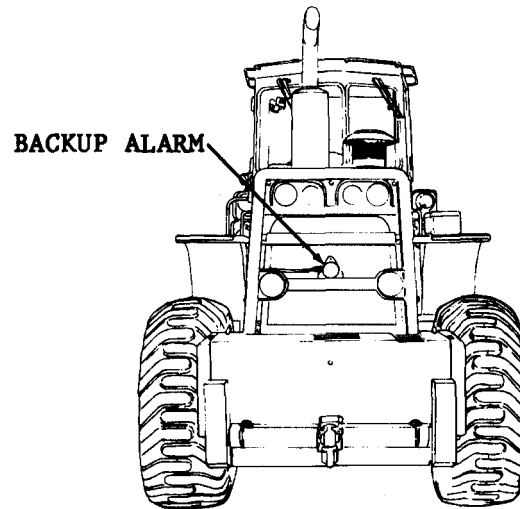

D Engine oil sample valve. Provides easy access to obtain an oil sample for testing.

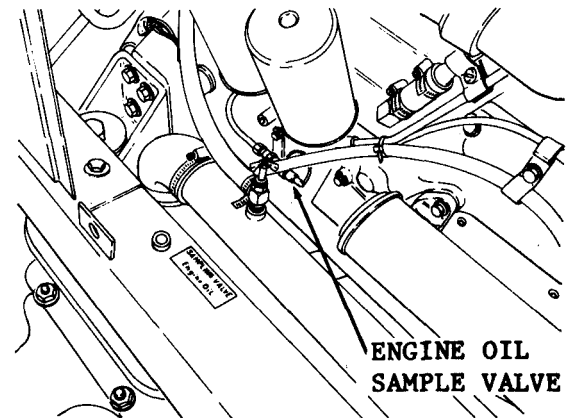

1-10 DIFFERENCE BETWEEN MODELS.-Continued
SERIAL NUMBER 2001 AND UP-Continued

TRANSMISSION OIL
SAMPLE VALVE

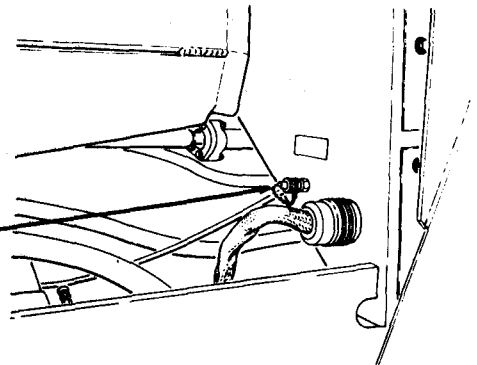

E Transmission oil sample valve. Provides easy access to obtain an oil sample for testing.

F Boom prop. A device mounted on the front main frame between the front wheels. It is for safety purposes and is to be used to support the boom anytime someone is working beneath the boom.

BOOM PROP

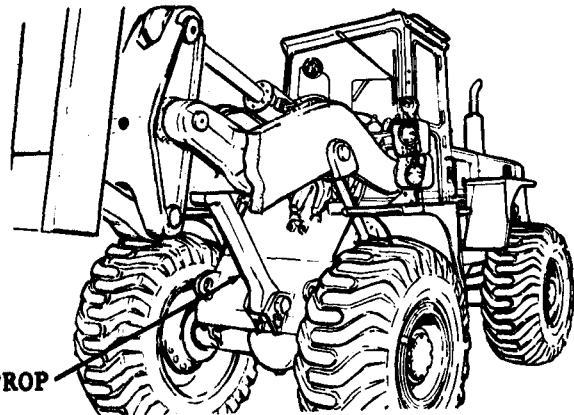

G Heater. Located in the cab and is used to provide heat in cold weather for operator comfort.

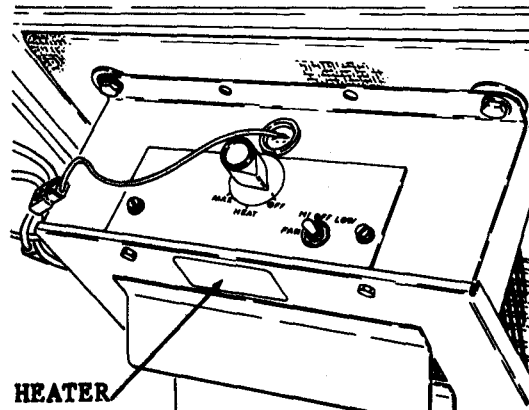

HEATER

H Defroster fans. Located on the ceiling of the cab are used to help keep inside of windows clear for better visibility.

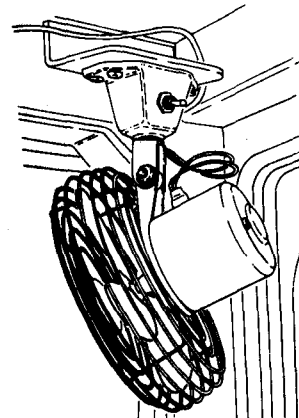

TA327896

1-10. DIFFERENCE BETWEEN MODELS.-Continued

SERIAL NUMBER 2001 AND UP-Continued

I Windshield wipers. Located on front and rear windows to help keep outside of windows clear for better visibility.

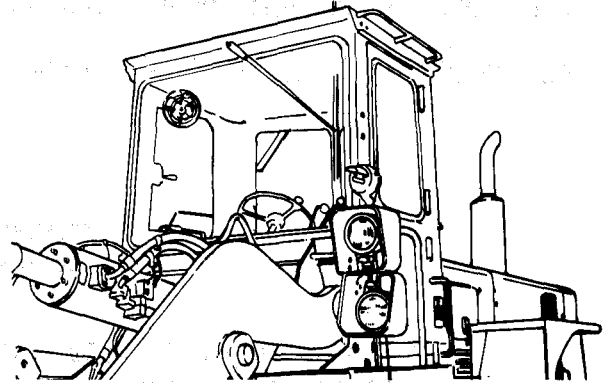

J Primary fuel filter and water separator. Located on the RH side of the engine. This fuel filter is also a water separator for fuel decontamination.

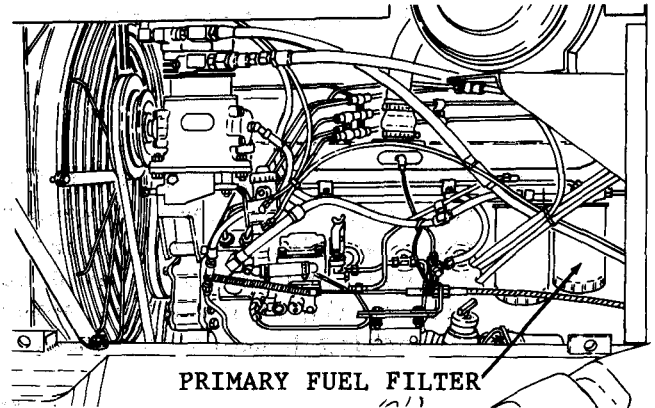

K Service brake pressure converter warning alarm sounds when hydraulic pressure drops too low for positive braking. Signal is located under right instrument panel.

PRESSURE CONVERTER WARNING ALARM

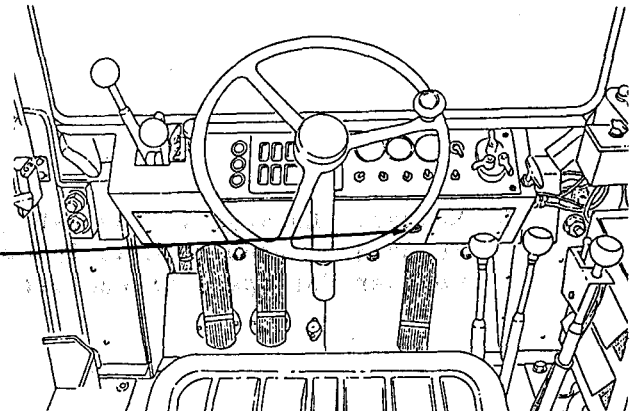

L Tool box. Located on the RH rear fender. Used for storage of small hand tools.

TOOL BOX

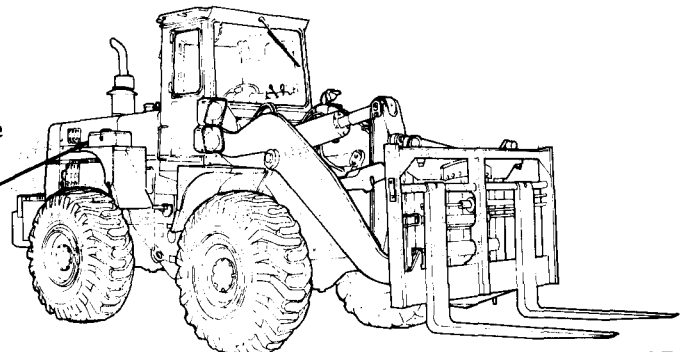

TA327897

1-10. DIFFERENCE BETWEEN MODELS.-Continued

M Ignition switches are located on the RH side of the instrument panel in the operator's compartment. S/N 2001 and above does not require a key. The cab door may be locked for security. S/N 2000 and below requires a key to operate.

S/N 2001 AND ABOVE

S/N 2000 AND BELOW

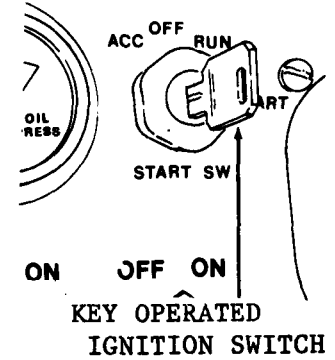
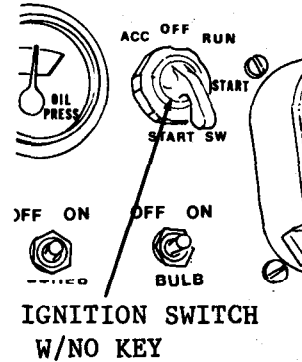

N S/N 2000 and below has a rain cap on the end of the exhaust pipe to provide protection against moisture. S/N 2001 and above utilize a curved exhaust pipe.

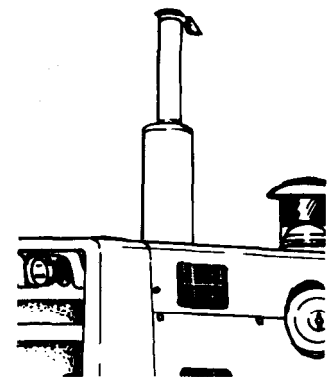
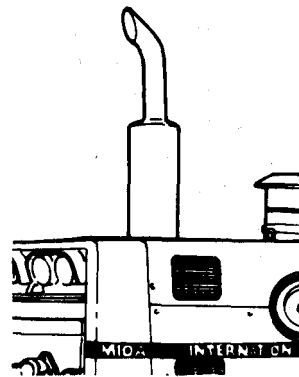

O Master disconnect switches are located on the LH side of the hydraulic reservoir. S/N 2001 and above need no key to operate. S/N 2000 and below is key operated for protection against theft and vandalism when the forklift is left unattended.

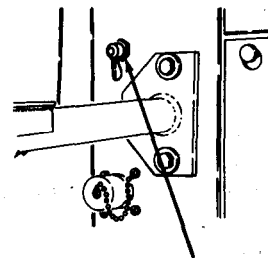

MASTER DISCONNECT W/NO KEY

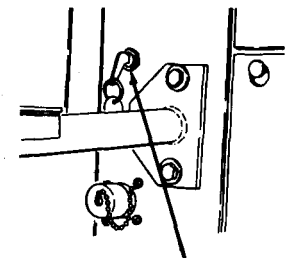

KEY OPERATED MASTER DISCONNECT

1-11 EQUIPMENT DATA.

a.	<u>Manufacturer.</u>	Dresser Industries
b.	<u>Model.</u>	M10A
c.	<u>Dimensions.</u>	
	Length (including fork)	344 inches
	Height with ROPS	131 inches
	Wheelbase	108 inches
	Width	101 inches
	Ground clearance	16.5 inches
	Fork length	72 inches
	Fork width	8 inches
	Lift height	121.6 inches
	Maximum rollback:	
	At ground	13 degrees
	At maximum height	56 degrees
	Reach below ground	8.8 degrees
	Forks together - minimum	
	inside to inside:	
	Machines with S/N 2000 and below	9 inches
	Machines with S/N 2001 and above	3 inches
	Forks spread - maximum -	
	outside to outside:	
	Machines with S/N 2000 and below	68 inches
	Machines with S/N 2001 and above	80 inches
	Fork carriage maximum side shift -	
	right or left	12 inches
	Fork carriage maximum oscillation -	
	right or left:	
	Machines with S/N 2000 and below	6 degrees
	Machines with S/N 2001 and above	7 degrees
	Pintle\hook height (center)	31.5 inches
d.	<u>Weight.</u>	
	No load weight, less operator,	
	with full fuel tank	36,500 pounds
	Rated load	10,000 pounds
e.	<u>Capacities.</u>	
	Fuel tank	60 gallons
	Cooling system	1 5 gallons
	Hydraulic system	14.5 gallons
	Transmission, torque converter	14 quarts
	Engine crankcase	22 quarts
	Axles (each)	32 quarts
	Steering gear	1 pint

Section III. PRINCIPLES OF OPERATION

1-12. ENGINE. Four-stroke turbocharged diesel engine with six cylinders.

1-13. FUEL SYSTEM.

Legend

- 1. Accelerator pedal
- 2. Fuel tank
- 3. Air cleaner
- 4. Ether start aid
- 5. Fuel level gage

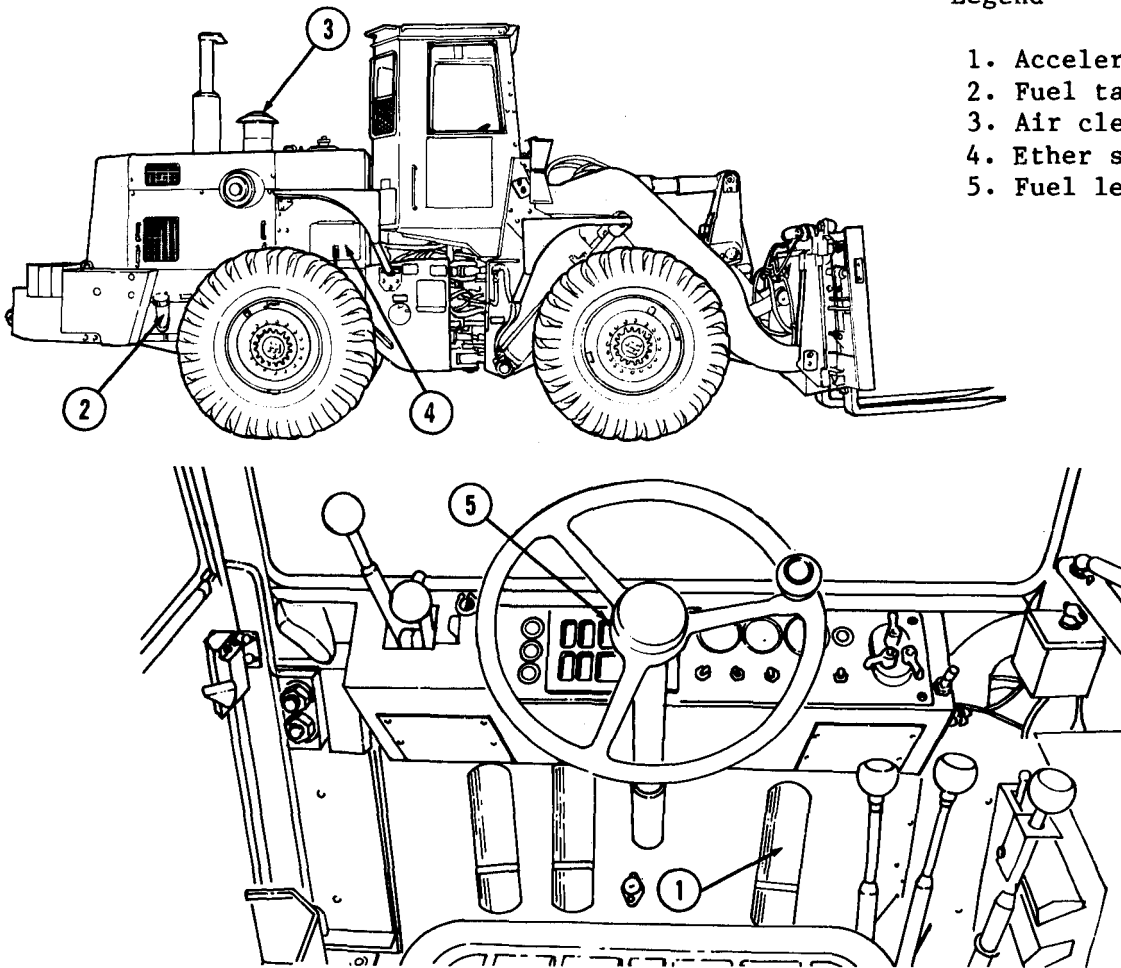

a. Accelerator Pedal (1). Depressing pedal with foot increases fuel flow and engine speed.

b. Fuel Tank (2). Holds approximately 60 gallons of diesel fuel.

c. Air Cleaner (3). Removes dust and dirt from air before it enters the engine. An air cleaner indicator located on top of hydraulic tank signals air cleaner servicing requirement.

d. Ether Start Aid (4). Injects a metered amount of ether into the engine to aid in cold weather starting.

e. Fuel Level Gage (5). Indicates the available fuel supply in the tank.

1-14. EXHAUST SYSTEM.

Legend

- 1. Rain cap
- 2. Exhaust pipe
- 3. Muffler

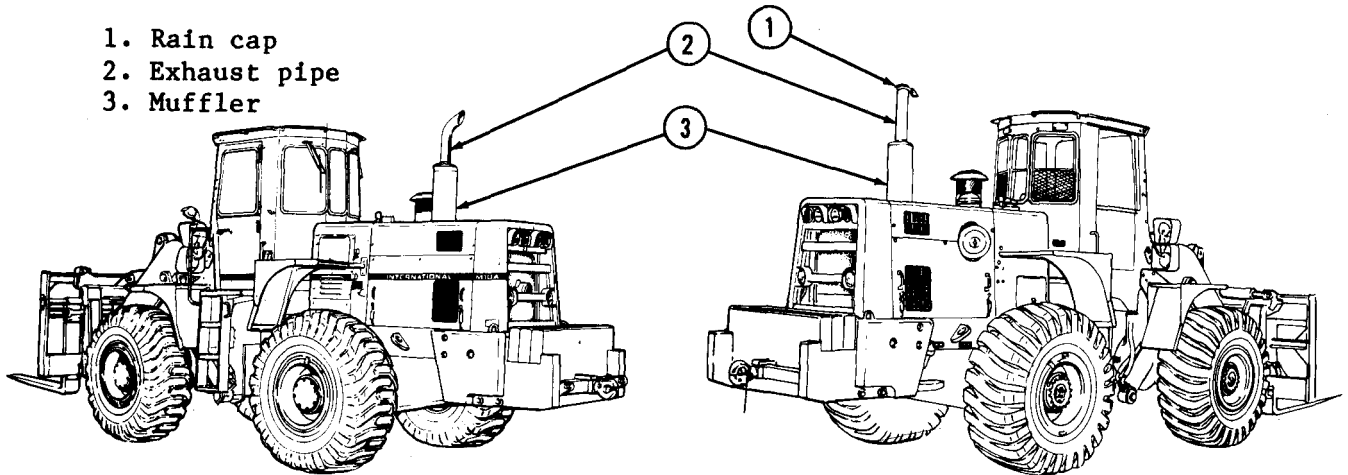

S/N 2001 AND ABOVE

S/N 2000 AND BELOW

- a. Rain Cap (1). S/N 2000 and below is equipped with a rain cap that protects exhaust system against moisture.
- b. Exhaust Pipe (2). Discharges engine exhaust into the atmosphere.
- c. Muffler (3). Muffles engine noise.

1-15. COOLING SYSTEM.

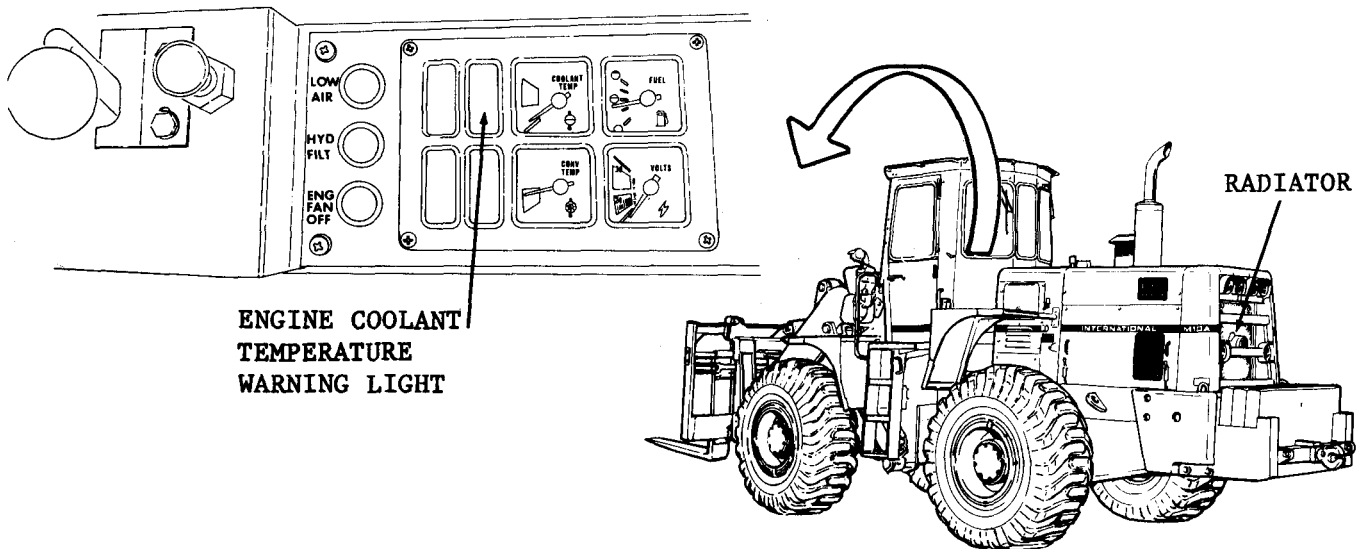

ENGINE COOLANT TEMPERATURE WARNING LIGHT

RADIATOR

- a. Radiator. 15 gallon capacity. Dissipates engine-generated heat.
- b. Warning Light. Located on left instrument console. Will light if coolant temperature becomes too high for safe operation.

1-16. ELECTRICAL SYSTEM.

a. Starting Circuit.

Legend

- 1. Battery
- 2. Master switch
- 3. Start switch
- 4. Starting motor

S/N 2000 AND BELOW

S/N 2001 AND ABOVE

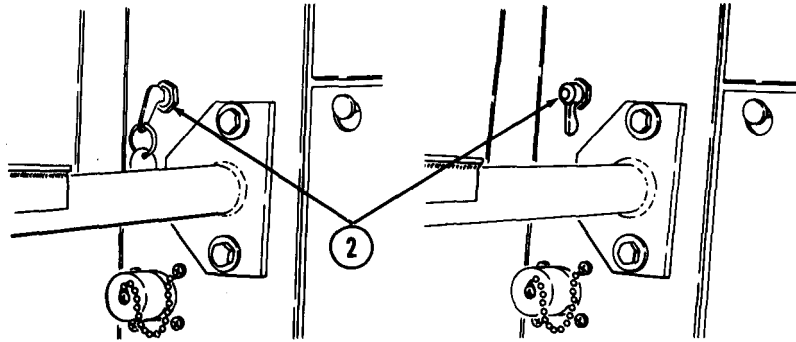

(1) Battery (1). Two 12-volt batteries connected in series provide 24 volts. Located on LH side of hydraulic reservoir.

(2) Master disconnect switch (2). Located on LH side of hydraulic reservoir above the LH rear fender. S/N 2000 and below uses key. S/N 2001 and above needs no key.

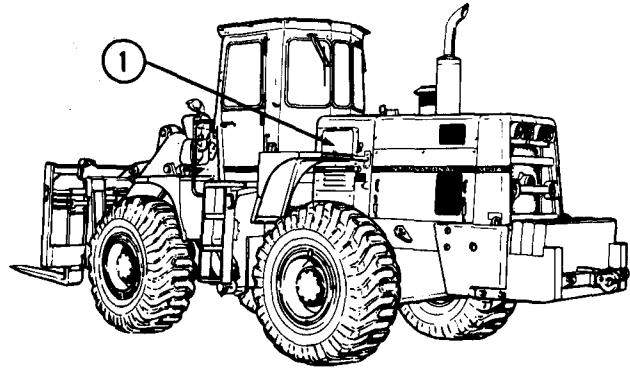

S/N 2000 AND BELOW

S/N 2001 AND ABOVE

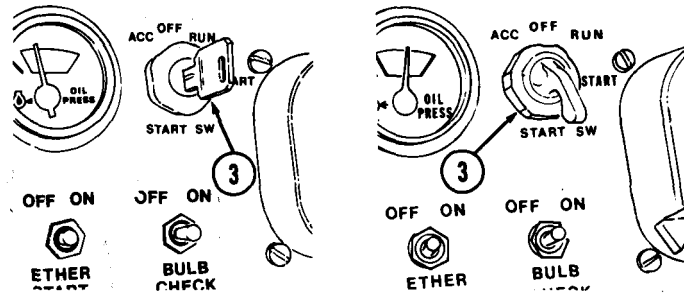

(3) Start switch (3). Located on right instrument console. Used to engage the starting motor. Has ACC position for operation of added electrical accessories.

(4) Starting motor (4). Located in engine compartment, right side, front. Starts engine. Activated by the start switch when the master switch is on and transmission is in neutral.

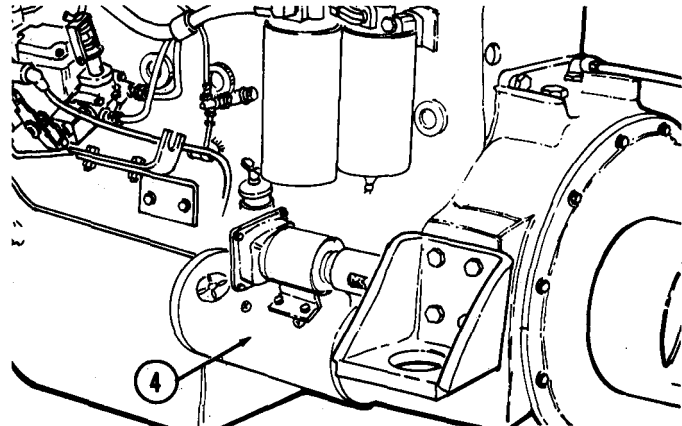

TA327901

1-16. ELECTRICAL SYSTEM.-Continued

b. Charging Circuit.

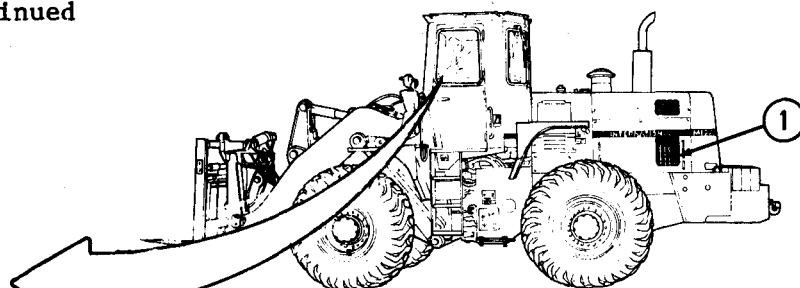
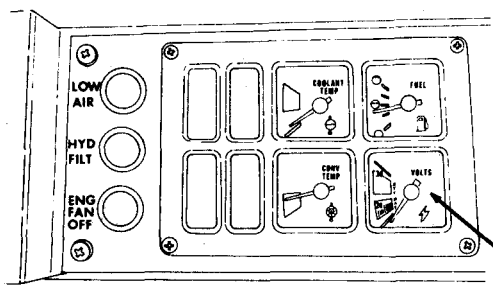

Legend

1. Alternator 2. Voltmeter

(1) Alternator (1). Maintains the voltage charge in the battery.

(2) Voltmeter (2). Located on left instrument console. With starting switch on RUN, pointer registers in low green area and indicates condition of batteries. With engine running and starting switch on RUN, pointer registers in high green area and indicates if the alternator is producing electric current.

c. Lighting Circuit.

Legend

1. Headlight
2. Front service lights
3. Rear service lights
4. Front blackout lights
5. Tail/stoplights
6. Rear blackout lights
7. Vehicle light switch
8. Front service light switch
9. Rear service light switch

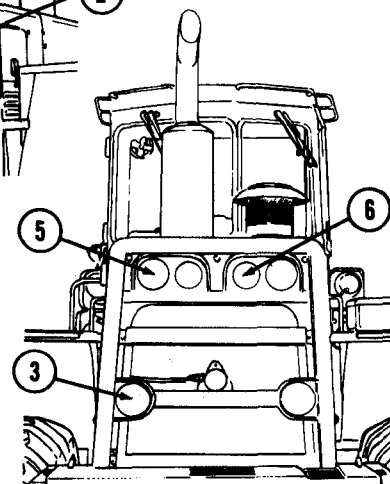
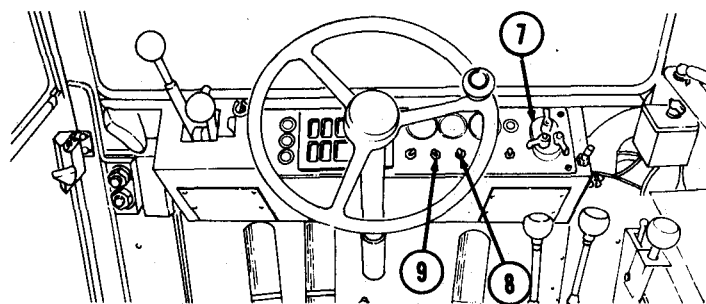
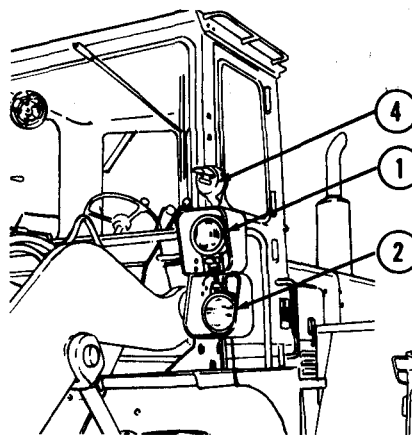

(1) Headlights (1). Two sealed beam type. Lights (1) provide low beam, controlled by the vehicle light switch assembly.

(2) Front service lights (2). Two sealed beam type for normal forward illumination. Controlled by the front service light switch.

(3) Rear service lights (3). Two sealed beam type for rear illumination controlled by the rear service light switch.

(4) Front blackout light (4). Provides forward blackout illumination during tactical operations.

TA327902

1-16. ELECTRICAL SYSTEM.-Continued

c. Lighting Circuit.-Continued

(5) Tail/stoplights (5). Two light assemblies mounted on the rear of the forklift. Provides normal stoplight and taillight illumination.

(6) Rear blackout lights (6). Two light assemblies mounted on the rear of the forklift. Provides stoplight and taillight, illumination during tactical operations.

(7) Vehicle light switch (7). Consists of three switches used to operate the vehicle lights.

(8) Front service light switch(8). Two position toggle switch used to operate the front service lights.

(9) Rear service light switch (9). Two position toggle switch used to operate the rear service lights.

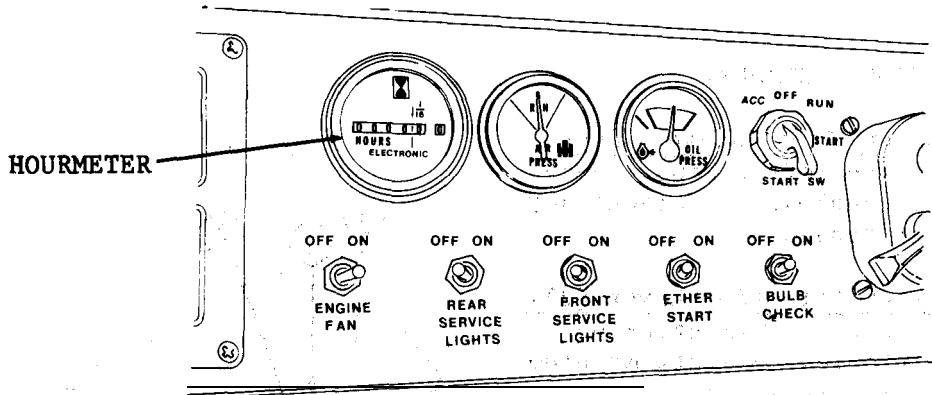

d. Hourmeter. Located on center instrument console. Indicates total service hours on the engine.

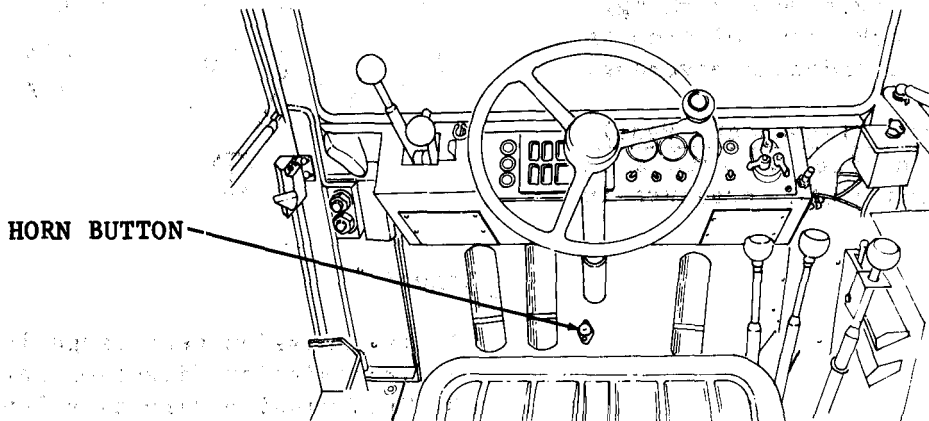

e. Horn Button. Located on floor. Used to sound the horn.

1-16. ELECTRICAL SYSTEM.-Continued

f. Backup Alarm. Models S/N 2001 and above.

(1) Backup alarm switch. When the transmission directional lever is moved to reverse, the backup alarm will sound.

(2) Alarm. Located center grille, rear of machine. Sounds to warn personnel the vehicle is backing up. A HIGH-LOW switch is located on the backside of the alarm. This switch should be left in the HIGH position.

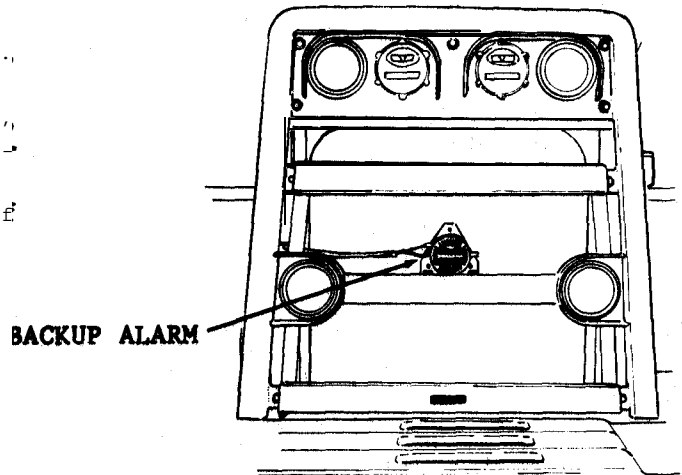

1-17. TRANSMISSION CONTROLS.

a. Transmission Gear Range Lever

(1). Located to the left of the steering wheel on the dashboard. Selects any of the three gear ranges.

b. Transmission Direction Lever (2).

Located to the left of the steering wheel on the dashboard. Selects machine direction or neutral position.

c. Transmission Control Lever Safety

Lock (3). Located in between transmission direction lever and parking/emergency brake. Locks transmission in neutral to prevent accidental movement.

Transmission Disconnect Pedal

(4). Located on the floor. Acts as a brake and also stops clutch pressure in the transmission.

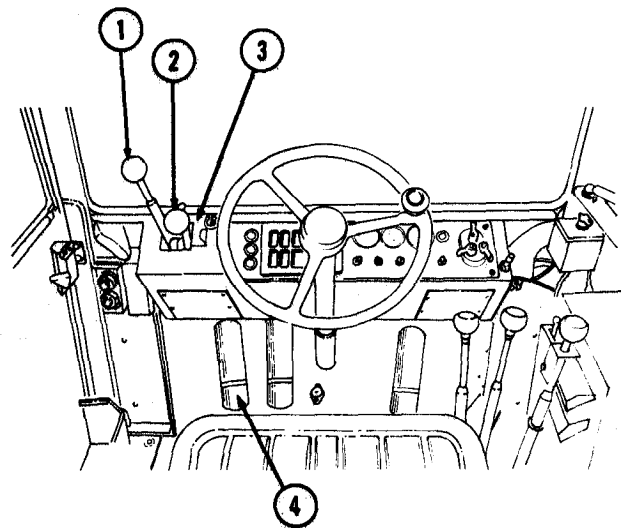

Legend

- 1. Transmission gear range lever
- 2. Transmission direction lever
- 3. Transmission direction lever safety lock
- 4. Transmission disconnect pedal

1-18. AIR SYSTEM.

Legend

- 1. Air compressor
- 2. Air tanks
- 3. Air pressure gage
- 4. Low air pressure indicator

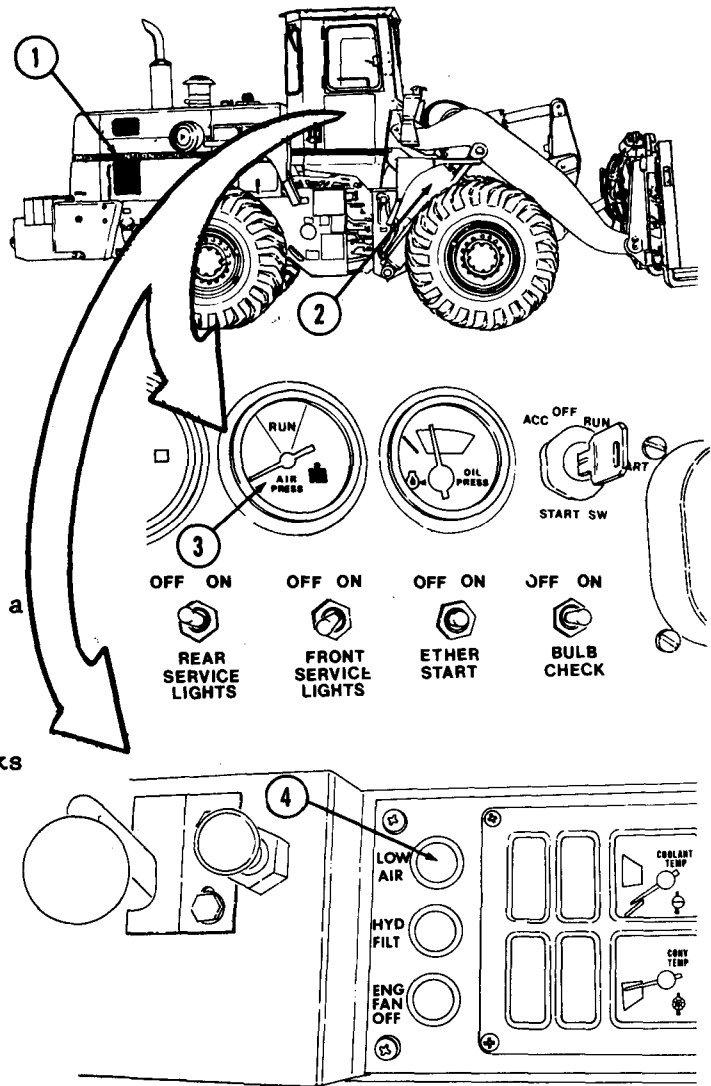

a. Air Compressor (1). Provides a supply of compressed air for use in vehicle brake systems.

b. Air Tanks (2). Provide a reservoir for compressed air. Air tanks are located in the front main frame above the front axle.

c. Air Pressure Gage (3). Air system pressure gage indicates air pressure in tanks.

d. Low Air Pressure Indicator (4). Lights and alarm sounds when pressure in the tanks is below normal, safe operating level (60 psi).

1-19. BRAKES .

Legend

1. Brake pedal
2. Service brake pressure converters
(S/N 2001 and above)/power
clusters (S/N 2000 and below)
3. Brake pads and discs
4. Service brake warning light
5. Pressure converter warning alarm
6. Parking/emergency brake control
7. Parking brake warning light
8. Parking brake warning alarm

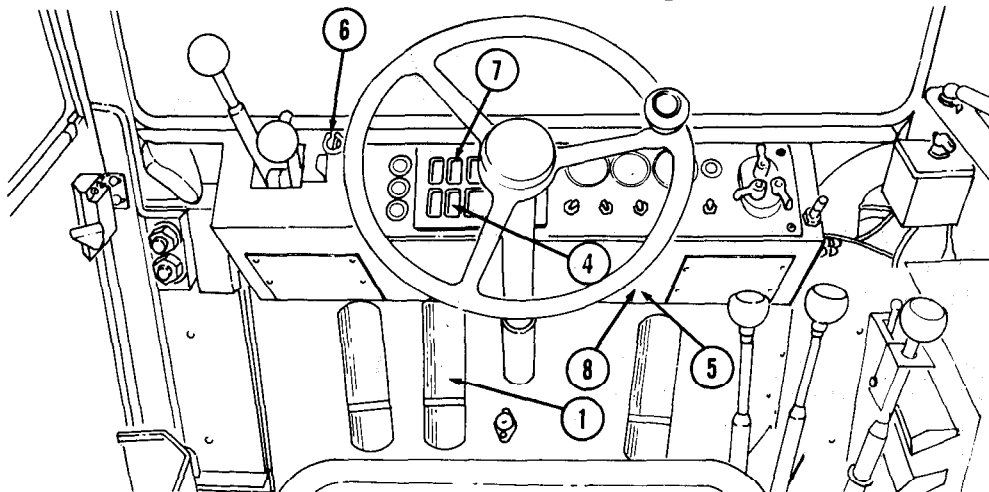
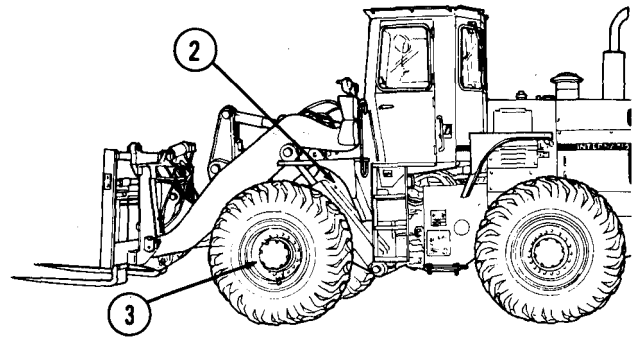

a. Service Brakes. An air over hydraulic disc brake system used to control and stop the vehicle.

(1) Brake pedal (1). Controls the brake treadle valve to direct air to the pressure converters.

(2) Service brake pressure converter (2). Converts air pressure to hydraulic pressure to engage the brakes.

(3) Brake pads and discs (3). Controlled by the pressure converter, the pads press against the discs for braking action.

(4) Service brake warning light (4). Will flash off and on, if brake hydraulic pressure drops to low for positive braking.

(5) pressure converter warning alarm (5). Alarm will sound when hydraulic pressure drops to low for positive braking.

b. Parking/Emergency Brake. A drum type, spring engaged, air disengaged brake used for parking and emergency stopping situations.

(1) Parking/emergency brake control (6). Used to set or release parking/emergency brake. Directs air to parking brake air cylinder.

1-19. BRAKES.-Continued

(2) Parking brake warning light (7). Will come on when the parking brake is applied.

(3) Parking brake warning horn (8). Will sound when the parking brake is applied.

1-20. STEERING. Steering is accomplished by articulation through the use of hydraulics.

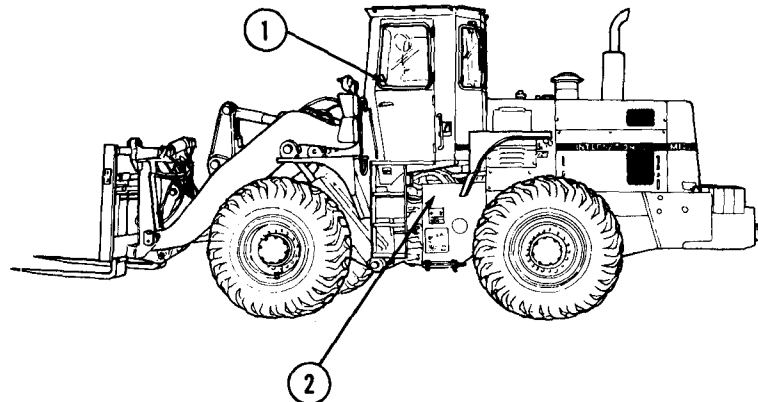

Legend

- 1. Steering wheel
- 2. Steering cylinders

a. Steering Wheel (1). Used to change direction of vehicle movement. Controls steering cylinders for articulation.

b. Steering Cylinders (2). One cylinder, on each side of the forklift. Used to articulate by pivoting the main frames at the center hinge.

1-21. HYDRAULIC SYSTEM AND IMPLEMENTS.

Legend

- 1. Reservoir
- 2. Lift control lever
- 3. Lift cylinder
- 4. Tilt control lever
- 5. Tilt cylinder
- 6. Sideshift, oscillate, and fork positioner control lever
- 7. Mode selector switch
- 8. Sideshift cylinder
- 9. Oscillate cylinder
- 10. Fork positioner cylinder
- 11. Fork carriage
- 12. Fork control lock

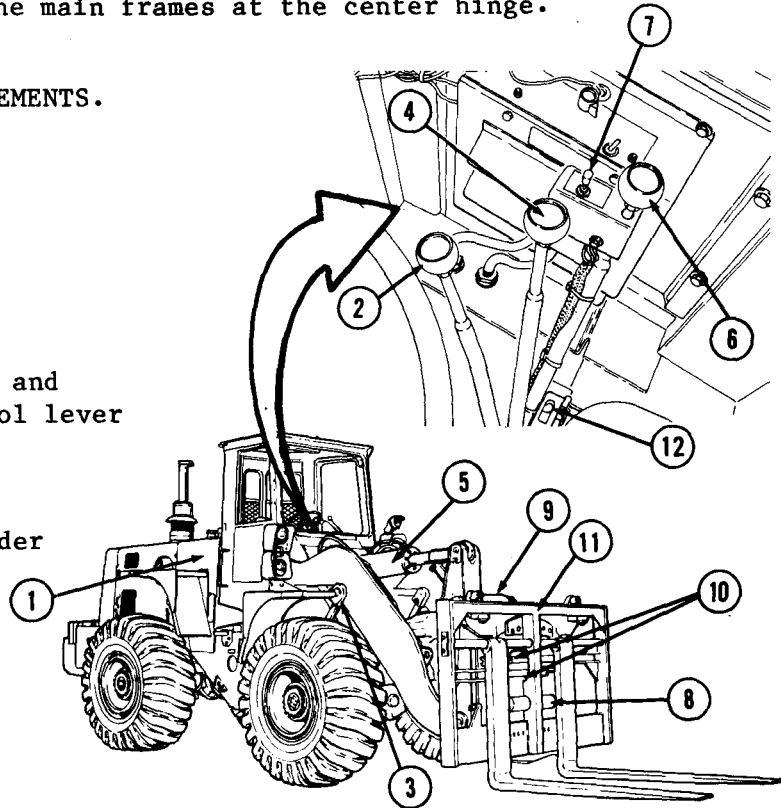

1-21. HYDRAULIC SYSTEM AND IMPLEMENTS.-Continued.

a. Reservoir (1). Provides hydraulic fluid supply for hydraulic system and steering. 14.5 gallon capacity.

b. Fork Carriage Cylinders and Controls.

(1) Lift control lever (2). Permits fork carriage to be raised, lowered, or held in position.

(2) Lift cylinder (3). Raising and lowering of the fork carriage is accomplished through the use of two hydraulic cylinders.

(3) Tilt control lever (4). Permits fork carriage to be tilted back, tilted forward, or held in position.

(4) Tilt cylinder (5). Tilting of the fork carriage is accomplished through the use of one hydraulic cylinder.

(5) Sideshift, oscillate, and fork positioner lever (6). Together with the attached mode selector switch (7) permits the following lever positions:

- . Forks apart
- . Hold
- . Forks together
- . Oscillate left side down
- . Hold
- . Oscillate right side down
- . Side shift left
- . Hold
- . Side shift right

(6) Sideshift cylinder (8). Left and right shifting of the fork carriage is accomplished through the use of one cylinder.

(7) Oscillate cylinder (9). Lowering of the left or right side of the fork carriage is accomplished through the use of one cylinder.

(8) Fork positioner cylinders (10). Spreading or closing of the forks is accomplished through the use of two cylinders.

(9) Fork carriage (11). Used to hold material while loading/unloading, or transporting.

(10) Fork control lock (12). Locks fork to prevent undesirable fork movement during operation.

CHAPTER 2

OPERATING INSTRUCTIONS

CHAPTER OVERVIEW

This chapter describes the operation of vehicle controls, switches, and indicators. It includes authorized Preventive Maintenance Checks and Services (PMCS) and step-by-step vehicle operating procedures.

INDEX

<u>Section</u>	<u>Title</u>	<u>Paragraph</u>	<u>Page</u>
I	DESCRIPTION AND USE OF OPERATOR'S CONTROLS AND INDICATORS		
	Operator's Compartment	2-1	2-3
	Instrument Console	2-2	2-4
	Steering Wheel and Hand Throttle Control	2-3	2-8
	Service Brakes, Brake and Transmission Disconnect Pedal and Accelerator	2-4	2-9
	Transmission Gear Range Lever, Transmission Direction Lever, and Transmission Safety Lock	2-5	2-9
	Lift Control Lever, Tilt Control Lever, and Fork Control Lock	2-6	2-10
	Sideshift, Oscillate, Fork Positioner Lever	2-7	2-10
	Mode Selector Switch	2-8	2-11
	Windows	2-9	2-11
	Heater Controls	2-10	2-12
	Defroster Fan Switches	2-11	2-12
	Windshield Wiper Control	2-12	2-12
	Rear Window Wiper Controls	2-13	2-12
	Air Cleaner Service Indicator	2-14	2-13
	Electrical System Master Disconnect Switch	2-15	2-13
	Coolant Level Sight Gage	2-16	2-13
	Engine Oil Dipstick	2-17	2-13
II	OPERATOR/CREW PREVENTIVE MAINTENANCE CHECKS AND SERVICES		
	Preventive Maintenance Checks and Services	2-18	2-14

INDEX-Continued

<u>Section Title</u>	<u>Paragraph Page</u>	
III	OPERATION UNDER USUAL CONDITIONS	
	Initial Adjustments, Daily Checks, and Self Test	2-19 2-31
	Operating Procedures	2-20 2-32
	Preparation for Movement	2-21 2-44
	Operating Instructions on Decals and Instruction Plates	2-22 2-45
IV	OPERATION UNDER UNUSUAL CONDITIONS	
	Operation in Unusual Weather	2-23 2-54
	Operation in Dusty or Sandy Areas	2-24 2-57
	Operation in Saltwater Areas	2-25 2-57
	Operation at High Altitudes	2-26 2-57
	Operation in Snow	2-27 2-57
	Fording	2-28 2-57

Section 1. DESCRIPTION AND USE OF OPERATOR'S CONTROLS AND INDICATORS.

Make sure you are familiar with the location and purpose of all controls, instruments, and indicators before operating the forklift.

2-1. OPERATOR'S COMPARTMENT

Legend

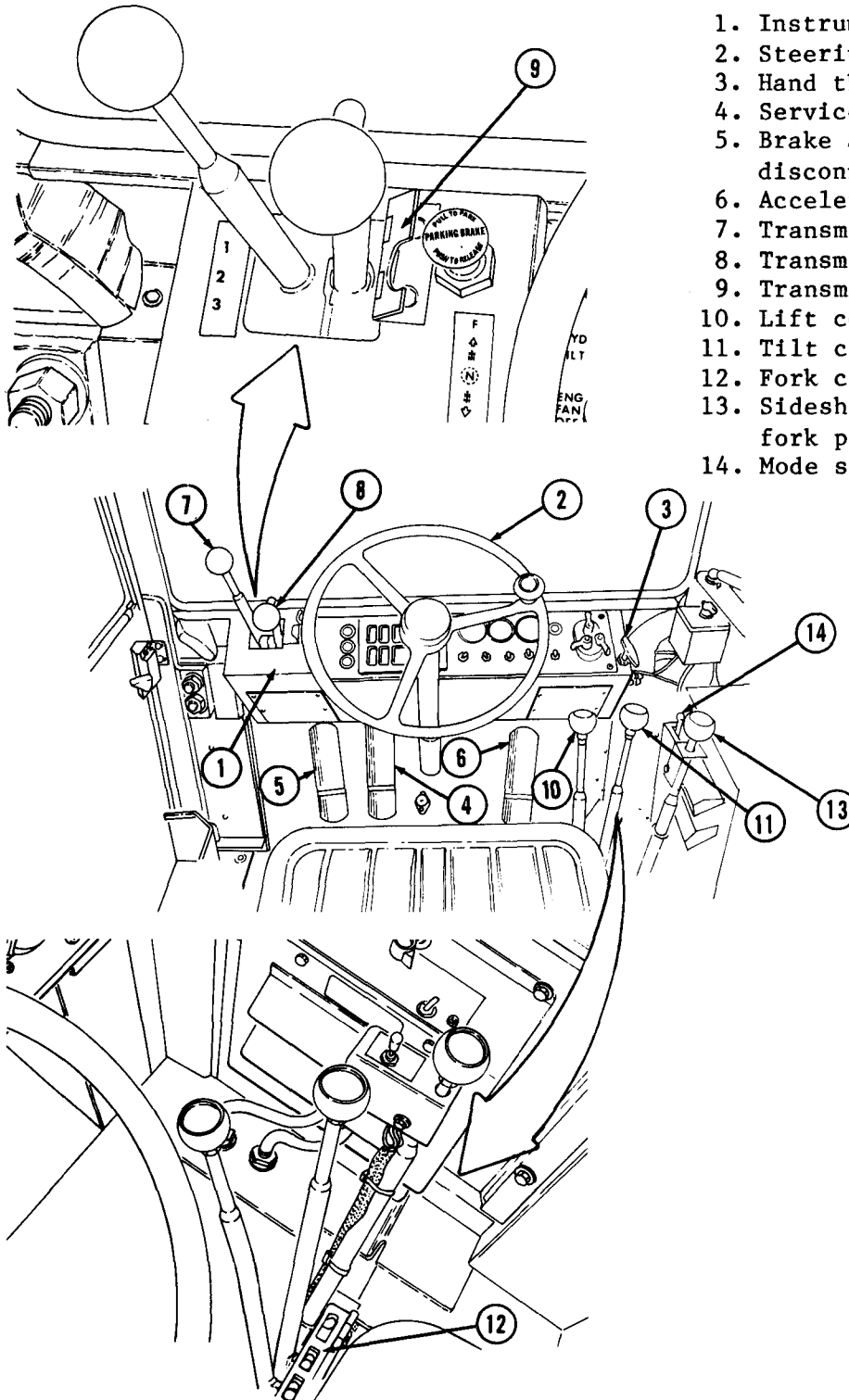

1. Instrument console
2. Steering wheel
3. Hand throttle control
4. Service brake
5. Brake and transmission disconnect pedal
6. Accelerator
7. Transmission gear range lever
8. Transmission direction lever
9. Transmission safety lock
10. Lift control lever
11. Tilt control lever
12. Fork control lock
13. Sideshift, oscillate, and fork positioner lever
14. Mode selector switch

TA327908

2-2. INSTRUMENT CONSOLE.

Legend

1. Engine oil pressure warning light
2. Parking brake warning light
3. Engine coolant temperature warning light
4. Service brake warning light
5. Torque converter temperature warning light
6. Ground driven steering warning light
7. Engine fan OFF light
8. Hydraulic filter warning light
9. Low air light

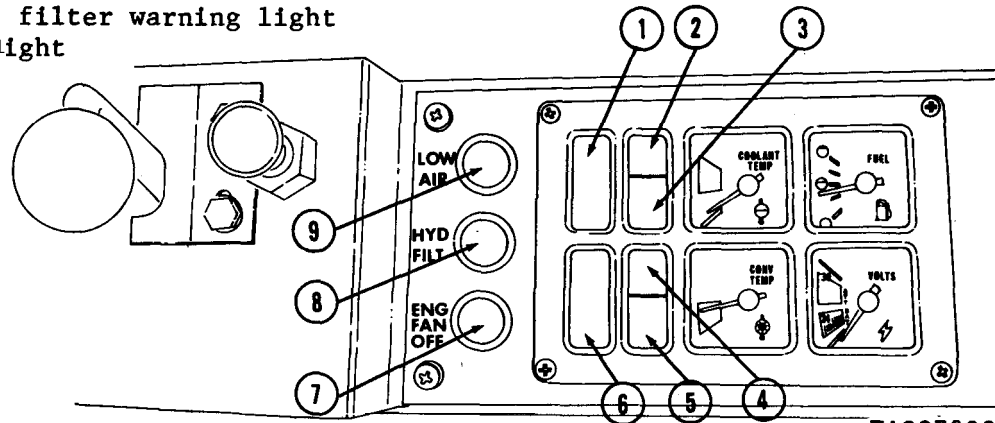

a. Indicators.

TA327909

(1) Engine oil pressure warning light (1). When lighted, the engine oil pressure is below normal.

(2) Parking brake warning light (2). This light will come on when the parking brake is applied and the starting switch is on. The parking brake horn will also sound.

(3) Engine coolant temperature warning light (3). When lighted, the engine coolant temperature is too high for safe operation.

(4) Service brake warning light (4). This light will flash on and off if the brake hydraulic pressure is too low for positive braking.

(5) Torque converter temperature warning light (5). When lighted, the torque converter oil temperature is too high for safe operation.

(6) Ground driven steering warning light (6). When lighted, the ground driven steering is operational, and the vehicle should be safely parked as soon as possible.

(7) Engine fan OFF light (7). When lighted, the engine fan is not operating.

(8) Hydraulic filter warning light (8). This light will come on if oil flow through the reservoir filter is restricted due to cold oil or a clogged filter.

(9) Low air light (9). When lighted, the air pressure in the system is below safe operating level.

2-2. INSTRUMENT CONSOLE.-Continued

b. Gages.

Legend

1. Engine coolant temperature gage
2. Fuel level gage
3. Hourmeter
4. Air pressure gage
5. Engine oil pressure gage
6. Voltmeter
7. Torque converter temperature gage

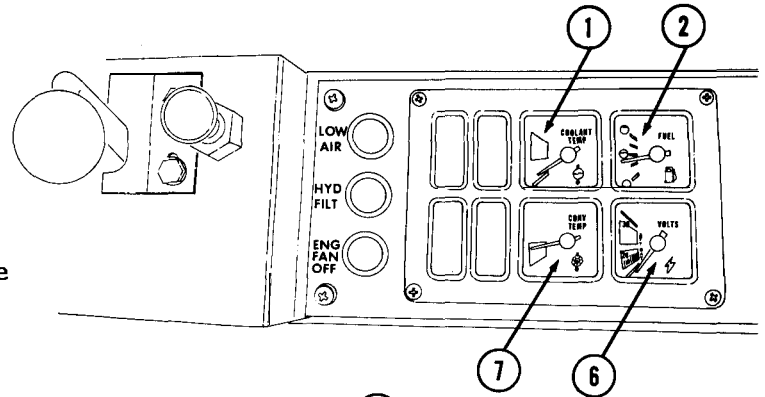

(1) Engine coolant temperature gage (1). Indicates the temperature of the coolant circulating through the engine. This gage should register in the RUN range during operation.

(2) Fuel level gage (2). Indicates the amount of fuel in the fuel tank. This gage is only accurate when the machine is parked on level ground.

(3) Hourmeter (3). Indicates the total service hours on the engine. Use it to determine service intervals.

(4) Air pressure gage (4). Indicates the air pressure available in the air tank. This gage must register in the RUN range for safe machine operation.

(5) Engine oil pressure gage (5). Indicates the pressure of the lubricating oil circulating through the engine. This gage must register in the RUN range when operating at full load speeds.

(6) Voltmeter (6). Indicates the condition of the battery when pointer is in the low green area. Indicates whether the alternator is charging when pointer is in the high green area.

(7) Torque converter temperature gage (7). Indicates the temperature of the fluid in the torque converter. This gage should register in the green range during operation.

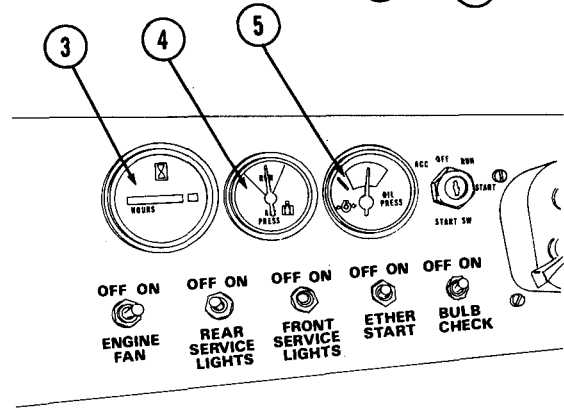

2-2. INSTRUMENT CONSOLE.-Continued

Legend

- 1. Parking/emergency brake control knob
- 2. Starting switch
- 3. Light switch
- 4. Bulb check switch
- 5. Ether start switch
- 6. Front service light switch
- 7. Rear service light switch
- 8. Engine fan switch

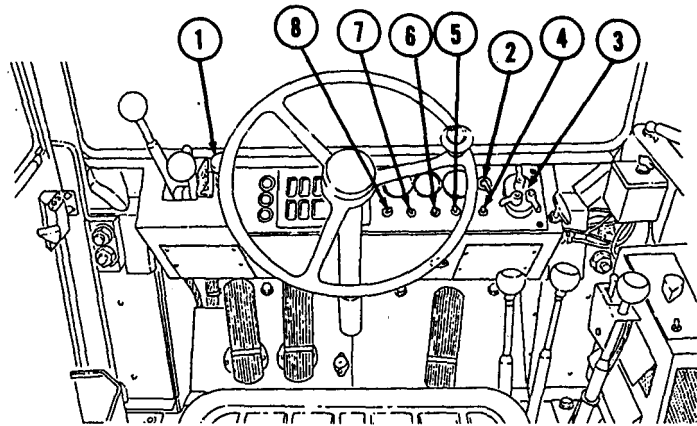

c. Switches.

- (1) Parking/emergency brake control knob (1).

WARNING

When the emergency brake is applied, be prepared for an abrupt stop.

(a) Engage. Pull the knob to set the parking brake. The parking brake should be set any time the operator leaves the operator compartment. While the parking brake is engaged, the parking brake warning light will be lit and the warning horn will sound, until the brake is released or the starting switch is shut off.

Pull the knob to apply the emergency brake, if the service brakes fail to stop the machine. The machine will stop abruptly when the emergency brake is applied.

(b) Release. Push the button in to release the brakes. The brakes will not release until there is ample air pressure in the system.

- (2) Starting switch (2).

Legend

- 1. ACC
- 2. OFF
- 3. RUN
- 4. START

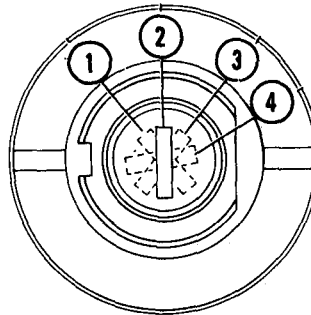

(a) The ACC position (1). Allows the use of added electrical accessories without the engine running.

(b) OFF position (2). Use this position when the machine is not being operated.

(c) RUN position (3). Switch will return to this position automatically when released from the START position. Will remain in this position.

(d) START position (4). Turn the switch to the far right to crank the engine. Engine will not start unless the master disconnect switch is on.

TA327911

(3) Light switch assembly (3).

(a) Main switch (1). Five position switch. Mechanical lock lever must be held in the UNLOCK position before moving the main switch lever to any position.

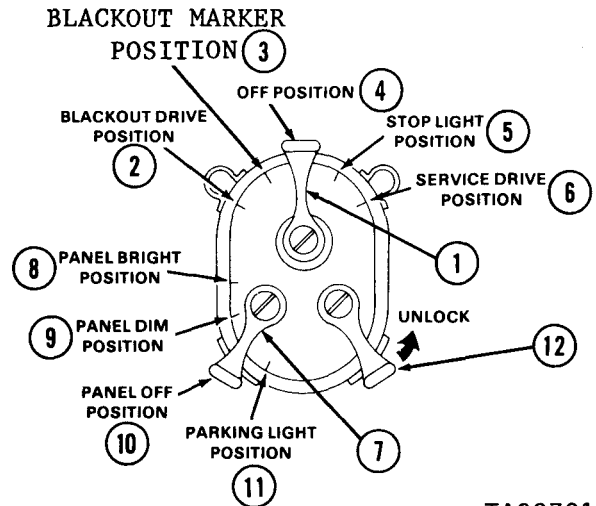

TA327912

NOTE

Master disconnect switch must be in the ON position for the vehicle light switch assembly to operate.

1 BLACKOUT DRIVE position (2). Blackout tail lights and blackout driving light lighted. Blackout stop light will light when brakes are applied.

2 BLACKOUT marker position (3). Blackout tail lamps lighted and stop lamp will light when brakes are applied.

3 OFF position (4). All lights off. Auxiliary switch(es) disabled.

4 STOP LIGHT position (5). Service brake lights will light when brake is applied.

5 SERVICE DRIVE position (6). Service tail light lighted. Brake lights will light when brakes are applied. Front headlights lighted. Front and rear service lights will light when front and rear service light switches are activated.

NOTE

Main switch must be in any position other than OFF for auxiliary switch to operate.

(b) Auxiliary switch (7). Four position switch.

1 PANEL BRIGHT position (8). Instrument panel lamps brightly lighted.

2 PANEL DIM position (9). Instrument panel lamps dimly lighted.

3 PANEL OFF position (10). Instrument panel lamps off. Service or blackout tail lamps off.

4 PARKING LIGHT position (11). Instrument panel lamps dimly lighted, Service tail lamps lighted (main switch in SERVICE DRIVE position). Blackout tail lamps lighted (main switch in BLACKOUT DRIVE position or BLACKOUT MARKER position).

2-2. INSTRUMENT CONSOLE.-Continued

(c) Mechanical switch (12). Spring loaded, two position switch.

1 LOCK position (unmarked). Prevents movement of main switch (A).

2 UNLOCK position. Enables movement of main switch (A). Hold lever in UNLOCK position and move main switch (3) to desired position.

(4) Bulb check switch (4). Use to check operation of instrument panel lights. Switch will return to OFF position when released. The oil pressure, ground driven steering, and low air lights are not checked by this switch.

(5) Ether start switch (5). Used in cold weather only to inject starting fluid (ether) into the intake manifold to aid in starting the engine. Push the button only while cranking the engine to inject a metered amount of starting fluid.

(6) Front service light switch (6). Controls the front service lights. Light switch (3) must be in the SERVICE DRIVE position before using this switch.

(7) Rear service light switch (7). Controls the rear service lights. Light switch (3) must be in the service drive position before using this switch.

Never operate forklift without the engine fan switch on except when water fording. Failure to operate fan will result in engine overheating and damage to engine.

Engage or disengage engine fan only when engine is operating at low idle.

(8) Engine fan switch (8). Controls the engine fan. Engine fan switch is always ON except when fording because water will enter fan sweep.

2-3. STEERING WHEEL AND HAND THROTTLE CONTROL.

a. Steering Wheel. Used to alter the direction of travel.

b. Hand Throttle Control. Used when a constant engine speed is desired. Pulling the handle out to increase engine speed, and turn the handle 1/4 turn to lock in that speed.

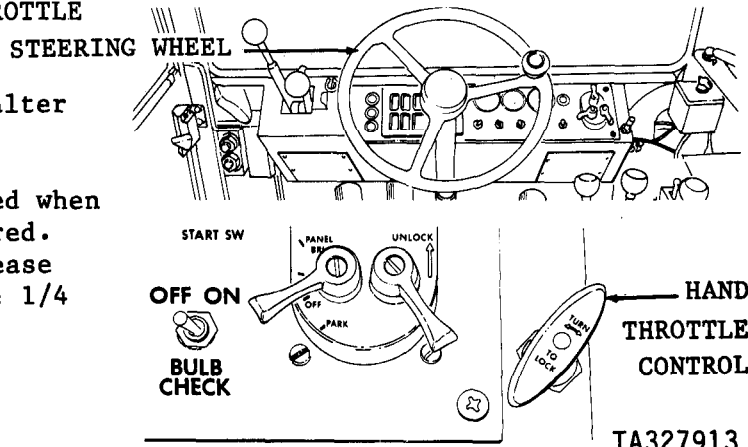

TA327913

2-4. SERVICE BRAKES, BRAKE AND TRANSMISSION DISCONNECT PEDAL AND ACCELERATOR.

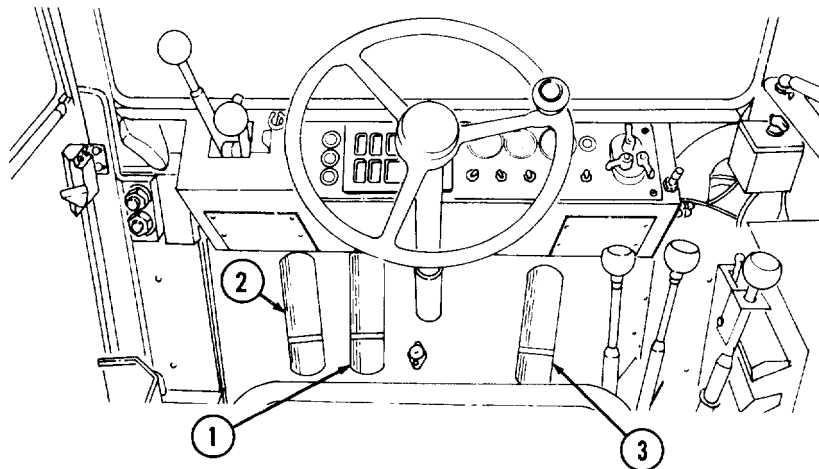

Legend

- 1. Service brake
- 2. Brake and transmission disconnect pedal
- 3. Accelerator

a. Service Brake (1). Slows and stops forklift.

b. Brake and Transmission Disconnect Pedal (2). Slows and stops forklift while disconnecting the transmission, to allow full power to forklift hydraulics.

c. Accelerator. Increases engine speed.

2-5. TRANSMISSION GEAR RANGE LEVER, TRANSMISSION DIRECTION LEVER, AND TRANSMISSION SAFETY LOCK.

a. Transmission Gear Range Lever (1). Used to select any of the three gear ranges. All three ranges can be used in forward and reverse.

b. Transmission Direction Lever (2). Used to select forward or reverse travel direction.

WARNING

Transmission safety lock must be engaged when vehicle is left unattended.

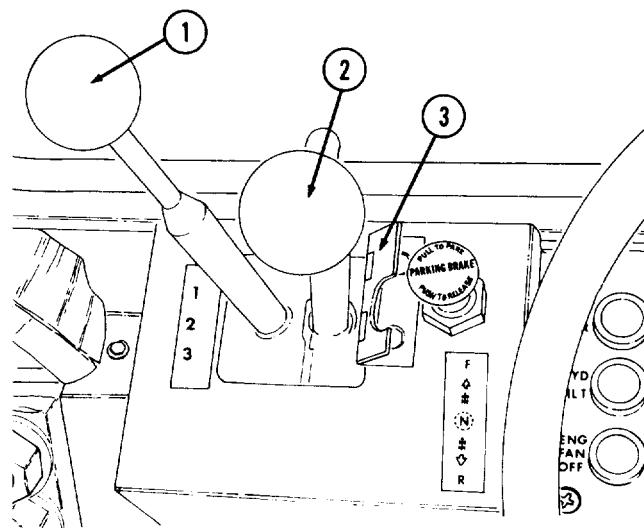

Legend

- 1. Transmission gear range lever
- 2. Transmission direction lever
- 3. Transmission safety lock

c. Transmission Safety Lock. Used to prevent movement of transmission direction lever and lock transmission in neutral.

2-6. LIFT CONTROL LEVER, TILT CONTROL LEVER, AND FORK CONTROL LOCK.

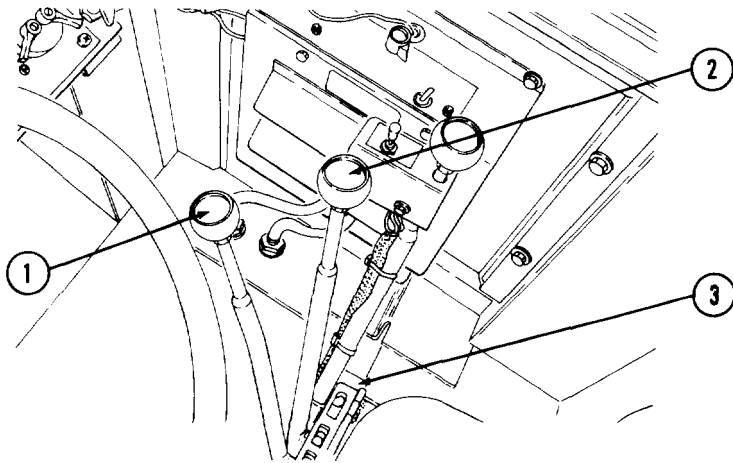

Legend

- 1. Lift control lever
- 2. Tilt control lever
- 3. Fork control lock

a. Lift Control Lever (1). Controls the raising and lowering of the forks by moving back to raise the forks, and moving forward to lower the forks. The lever will always return to hold when released, and the forks will stay in the attained position.

b. Tilt Control Lever (2). Controls the tilting of the forks.

c. Fork Control Lock (3). Moves over control levers to lock in neutral.

2-7. SIDESHIFT, OSCILLATE, AND FORK POSITIONER LEVER (1). Controls the three following movements of the forks depending on the selection of the mode switch.

a. Sideshift. Movement of the lever in this mode will result in a shift of the entire fork carriage, either to the right or the left. Forward will shift to the left, and back will shift to the right.

b. Oscillate. Movement of the lever in this mode will result in a rocking movement of the fork carriage with either the right or left fork being lower than the other. Forward will lower the left fork and back will lower the right fork.

c. Fork Positioner. Movement of the lever in this mode will result in a movement of the forks, either away from each other, or closer to each other. Forward will move the forks away from each other, back will move the forks closer to each other.

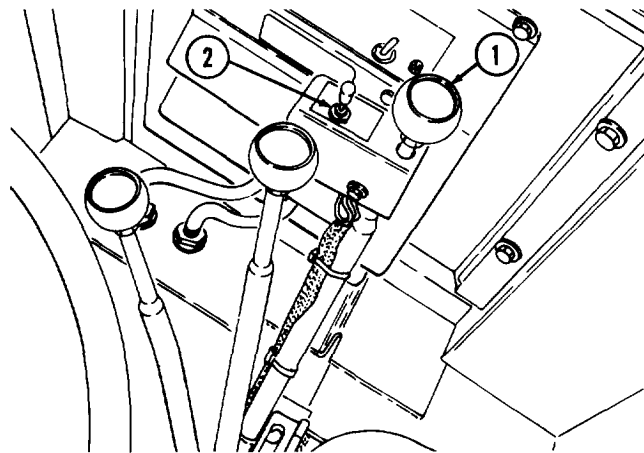

Legend

- 1. Three movement lever
- 2. Mode selector switch

TA327915

2-8. MODE SELECTOR SWITCH (2). Selects one of three modes of fork operation.

a. Rear Position. Selects the sideshift mode of operation.

b. Middle Position. Selects the oscillation mode of operation.

c. Forward Position. Selects the lateral movement mode of operation. To attain this switch position, the toggle lever cap must be pulled up and pushed forward at the same time

2-9. WINDOWS. Serial number 2001 and above. May be opened to provide ventilation in cab.

a. Left Hand Side Window. Secures with window latch. Opens out to rear. Secures in open position with window retainer on outside of cab. Window retainer releases with lever at left rear of cab.

b. Right Hand Side Window. Secures with window latch (1). Opens out to rear. Secures in open position by tightening knob (3) on window control rod (2).

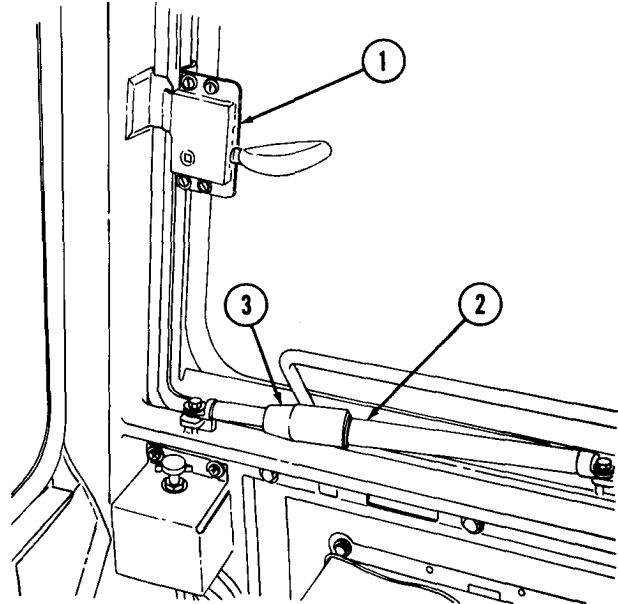

TA327916

Legend

- 1. Window latch
- 2. Window control rod
- 3. Knob

2-10. HEATER CONTROLS. Serial number 2001 and above.

a. Heater Temperature Control Knob. Used to turn the heater on and obtain the desired temperature.

b. Heater fan speed switch. Selects the speed of the heater fan. The switch has three positions.

(1) Forward position. High speed (HI).

(2) Center position. OFF.

(3) Rear position. LOW speed.

2-11. DEFROSTER FAN SPEED SWITCHES. Serial number 2001 and above. Located on the two defroster fan bases. These switches have three positions.

a. Left. High speed.

b. Center. Off.

c. Right. Low speed.

2-12. WINDSHIELD WIPER CONTROL. Serial number 2001 and above. Located to the right of the instrument console this knob is the windshield wiper OFF, ON, and speed control.

2-13. REAR WINDOW WIPER CONTROLS. Serial number 2001 and above. Located above the rear windows, in the center, between the left and right rear windows. Each knob controls OFF, ON and wiper speed for the nearest wiper.

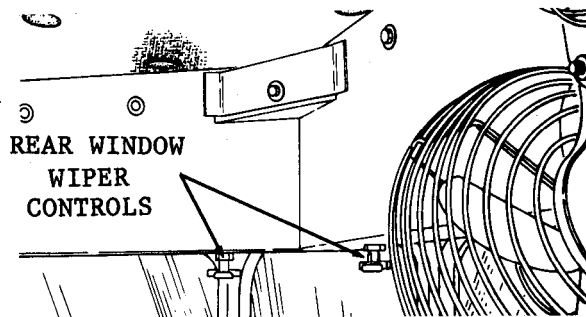
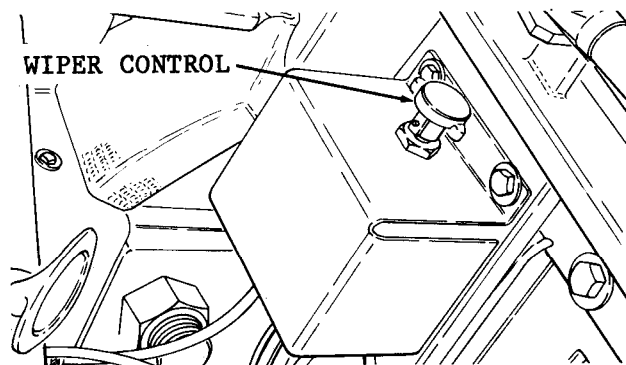
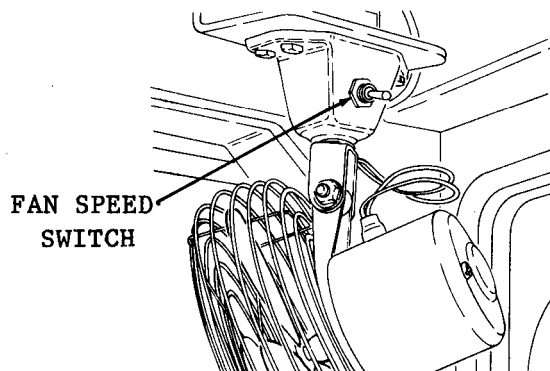
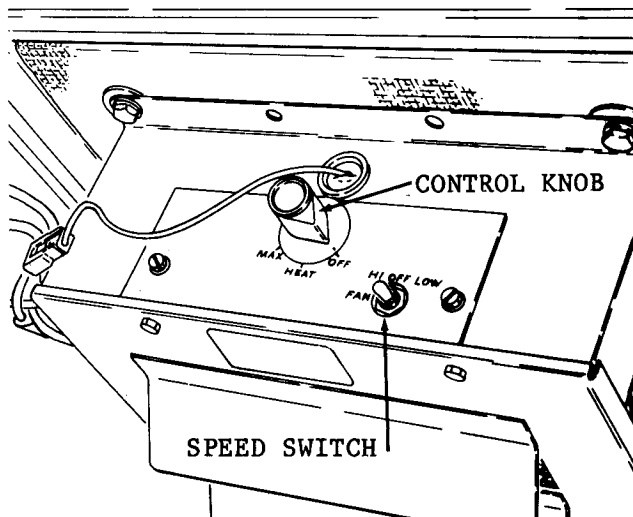

TA327917

2-14. AIR CLEANER SERVICE INDICATOR. Located on top of the reservoir to the left of the reservoir fill cap. It determines when the air filter is to be serviced.

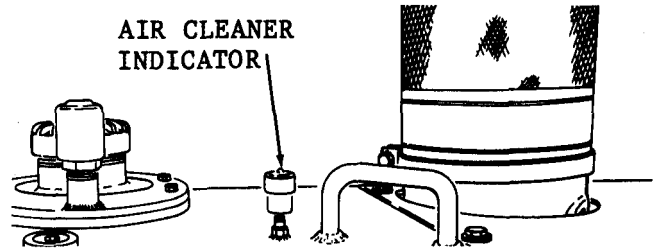

CAUTION

Electrical system will be damaged if master disconnect switch is left OFF with engine running. The batteries will discharge if master disconnect switch is left ON with engine not running.

2-15. ELECTRICAL SYSTEM MASTER DISCONNECT SWITCH. Located on the left side of the hydraulic reservoir next to the battery box. When turned to OFF will deactivate the forklift's entire electric system. If left ON when the forklift is not running, the batteries will discharge. If left OFF with engine running, the electrical system will be damaged.

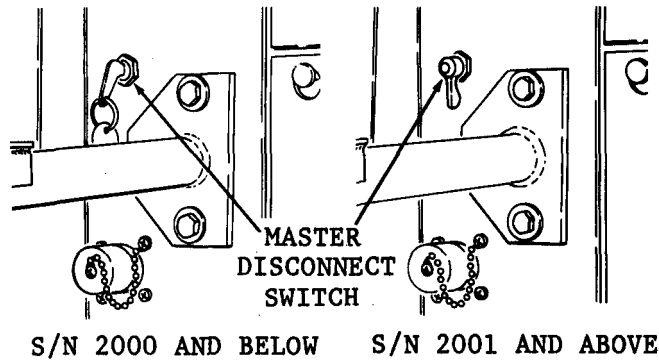

2-16. COOLANT LEVEL SIGHT GAGE. Located at the top rear of the radiator, coolant is viewed through the gage. The coolant level must be visible in the gage.

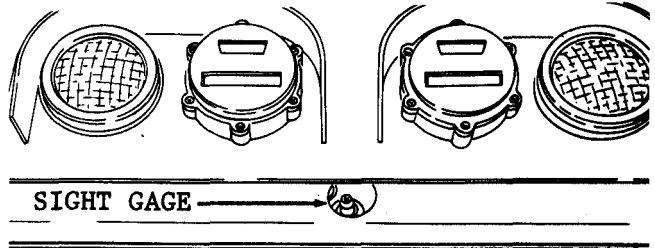

2-17. ENGINE OIL DIPSTICK. Located on the right side of the engine.

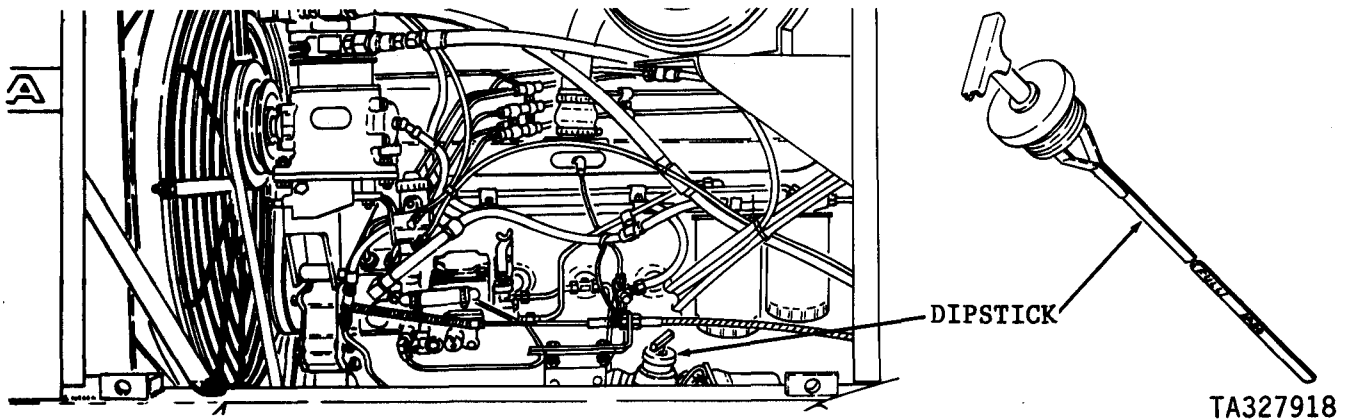

Section II. OPERATOR/CREW
PREVENTIVE MAINTENANCE CHECKS AND SERVICES (PMCS)

2-18. PREVENTIVE MAINTENANCE CHECKS AND SERVICES.

GENERAL

Your Preventive Maintenance Checks and Services Table lists the inspections and care of your equipment required to keep it in good operating condition.

OPERATOR/CREW PREVENTIVE MAINTENANCE CHECKS AND SERVICES

1. The number column of your PMCS is the source for the number used on the TM Number Column on DA Form 2407.
2. The interval column of your PMCS Table tells you when to do a certain check or service.
 - a. Before you operate. Perform your before (B) PMCS. Always keep in mind the WARNINGS and CAUTIONS.
 - b. While you operate. Perform your during (D) PMCS. Always keep in mind the WARNINGS and CAUTIONS.
 - c. After you operate. Be sure to perform your after (A) PMCS.
 - d. Once a week. Perform your weekly (W) PMCS. Always keep in mind the WARNINGS and CAUTIONS.
3. The procedure column of your PMCS Table tells you how to do the required checks and services. Carefully follow these instructions. If you do not have the tools, or if the procedure tells you to, have organizational maintenance do the work.
4. If your equipment does not perform as required, refer to the troubleshooting section in this manual for possible problems. Report any malfunctions or failures on the proper DA Form 2404 or refer to DA Pamphlet 738-750.

NOTE

The terms ready/available and mission capable refer to the same status: Equipment is on hand and is able to perform its combat missions (see DA Pamphlet 738-750).

5. Equipment is NOT READY/AVAILABLE IF: column. This column tells you when and why your equipment cannot be used.
6. Always do your PMCS in the same order so it gets to be a habit. Once you've had some practice, you will spot anything wrong in a hurry.
7. When you do your PMCS, take along a rag or two.

2-18. PREVENTIVE MAINTENANCE CHECKS AND SERVICES.-Continued

8. While performing PMCS, observe WARNINGS and CAUTIONS preceding those operations which could endanger your safety or result in damage to the equipment.

WARNING

Dry cleaning solvent, P-D-680, is toxic and flammable. Wear protective goggles and gloves and use only in well-ventilated area. Avoid allowing solvent to contact skin, eyes, and clothes, and don't breathe vapors. Do not use near open flame or excessive heat. If you become dizzy while using cleaning solvent, get fresh air immediately and get medical aid. If solvent comes in contact with skin or clothing, wash with water. If solvent gets in your eyes, flush eyes with water and get medical aid immediately. Flash point of solvent is 100°-1380F (38°-590c).

a. Keep it clean. Dirt, grease, oil and debris only get in the way and may cover up a serious problem. Clean as you work and as needed. Use dry cleaning solvent (P-D-680) to clean metal surfaces. Use soap and water when you clean rubber or plastic material.

b. Bolts, nuts, and screws. Check that they are not loose, missing, bent or broken. You can't try them all with a tool, of course, but look for chipped paint, bare metal or rust around bolt heads. Tighten any bolt, nut, or screw that you find loose.

c. Welds. Look for loose or chipped paint, rust, or gaps where parts are welded together. If you find a bad weld, report it to organizational maintenance.

d. Electric wires and connectors. Look for cracked or broken insulation, bare wires and loose or broken connectors. Report damaged or loose wiring to organizational maintenance.

e. Hoses and fluid lines. Look for wear, damage and leaks. Make sure clamps and fittings are tight. Wet spots show leaks, of course, but a stain around a fitting or connector can mean a leak. If leakage comes from a loose fitting or connector, tighten the fitting or connector. If something is broken or worn out, report it to organizational maintenance.

f. Vehicle must be on level ground in order to get correct fluid level measurement.

9. It is necessary for you to know how fluid leaks affect the status of your equipment. The following are definitions of the types/classes of leakage you need to know to be able to determine the status of your equipment. Learn and be familiar with them and REMEMBER - when in doubt, notify your supervisor.

2-18. PREVENTIVE MAINTENANCE CHECKS AND SERVICES.-Continued

LEAKAGE DEFINITIONS FOR OPERATOR/CREW PMCS

Class I Seepage of fluid (as indicated by wetness or discoloration) not great enough to form drops.

Class II Leakage of fluid great enough to form drops, but not enough to cause drops to drip from the item being checked/inspected.

Class III Leakage of fluid great enough to form drops that fall from the item being checked/inspected.

CAUTION

Equipment operation is allowable with minor leakages (Class I or II). Of course, consideration must be given to the fluid capacity in the item/system being checked/inspected. When operating with Class I or II leaks, continue to check fluid levels as required on your PMCS. Class III leaks should be reported to your supervisor or organizational maintenance.

Operator/Crew Preventive Maintenance Checks and Services

NOTE : Within designated interval, these checks are to be performed in the order listed.

B - Before D - During A - After W - Weekly

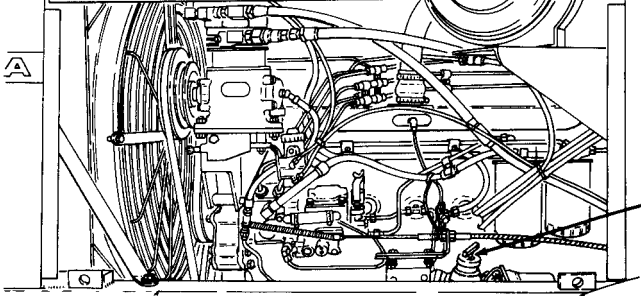
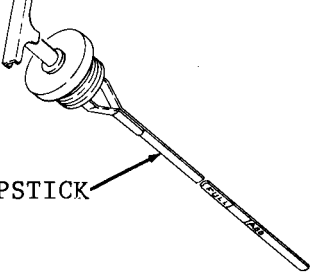
Item NO.	Interval B D A W	Item To Be Inspected Procedure: Check and have repaired, filled or adjusted as needed.	Equipment Is NOT READY/AVAILABLE IF:
1	●	<p>IMPORTANT: PERFORM WEEKLY (W) AS WELL AS BEFORE (B) OPERATIONS PMCS IF:</p> <ol style="list-style-type: none"> You are the assigned operator and have not operated the vehicle since the last weekly PMCS. You are operating the vehicle for the first time. <p>EXTERIOR OF FORKLIFT</p> <ol style="list-style-type: none"> Check for oil, brake fluid, fuel, coolant and hydraulic, leaks or appearance of leaks. Visually check Rollover Protective Structure (ROPS) or cab for obvious damage, bends and cracks in weldment. Visually check forks, carriages, and side shifter frame for cracked, bent or broken frame members. Visually check wiring harness and connections for frayed or broken wires. 	<p>Class III leaks.</p> <p>Obvious damage, bends and cracks in weldment.</p> <p>Forks, carriage, or side shifter frame are cracked, bent or broken.</p> <p>Wiring is frayed, broken.</p>
2	●	<p>ENGINE LEVEL</p>  <p>Check level on dipstick. Maintain oil level to between ADD and FULL mark.</p>	 <p>TA327919</p>

Operator/Crew Preventive Maintenance Checks and Services

NOTE : Within designated interval, these checks are to be performed in the order listed.

B - Before D - During A - After W - Weekly

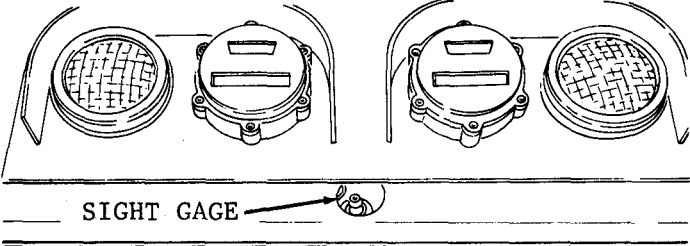
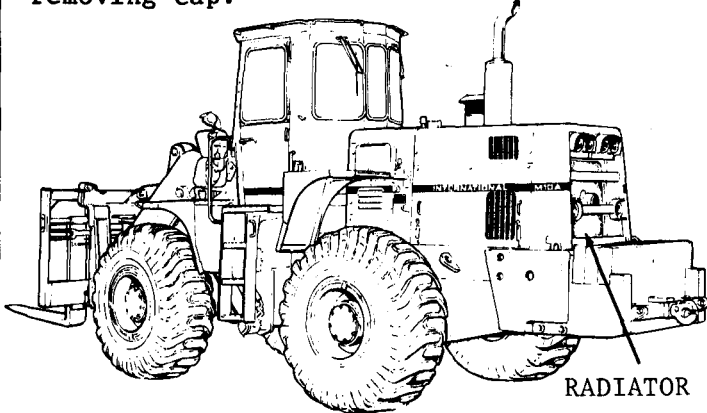
Item No.	Interval				Item To Be Inspected Procedure: Check and have repaired, filled or adjusted as needed.	Equipment Is NOT READY/AVAILABLE IF:
	B	D	A	W		
3					<p>RADIATOR</p>  <p>WARNING</p> <p>Cooling system is pressurized. Remove cap slowly and only when engine is cool or painful burns could result.</p> <p>a. Visually check coolant fluid at sight gage. If not visible, check by removing cap.</p>  <p>RADIATOR</p> <p>b. Visually check for and remove any debris or blockage of air flow through the radiator. Check for damage to core, bent fins.</p>	<p>No coolant visible.</p> <p>Damage to core or bent fins.</p>

TA327920

Operator/Crew Preventive Maintenance Checks and Services

NOTE : Within designated interval, these checks are to be performed in the order listed.

B - Before D - During A - After W - Weekly

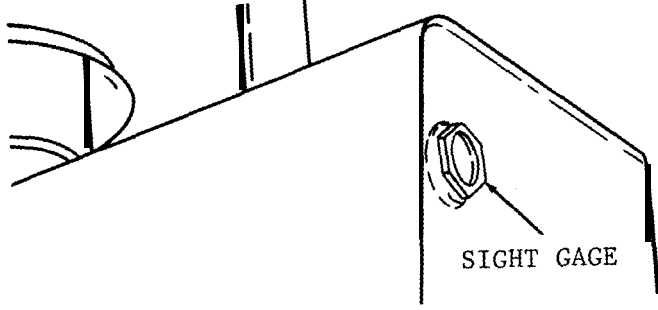
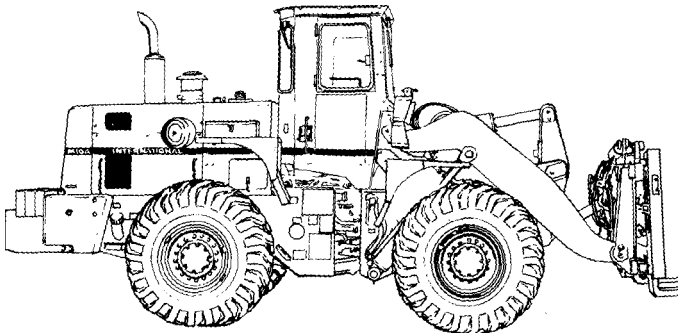
Item No.	Interval				Item To Be Inspected Procedure: Check and have repaired, filled or adjusted as needed.	Equipment Is Not READY/AVAILABLE IF:
	B	D	A	W		
4					<p>HYDRAULIC RESERVOIR</p>  <p style="text-align: center;">WARNING</p> <p>Turn hydraulic reservoir cap slowly before opening/releasing pressure.</p> <p>With boom lowered, check reservoir oil level at sight gage. Maintain oil so that float is in view of sight gage. Refer to LO 10-3930-643-12.</p>	
5					<p>TIRES AND WHEELS</p>  <p>a. Visually check tires for excessive wear, foreign objects, cuts or abrasions and obviously low or flat condition. Refer to TM 9-2610-201-14.</p>	<p>Tires have cuts abrasions which would result tire failure or tire is flat</p>

TA327921

Operator/crew preventive Maintenance Checks and Services

NOTE: Within designated interval, these checks are to be performed in the order listed.

B - Before D - During A - After W - Weekly

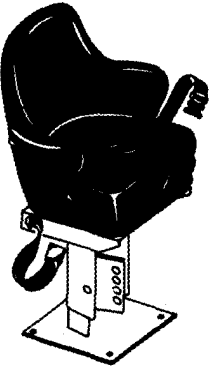
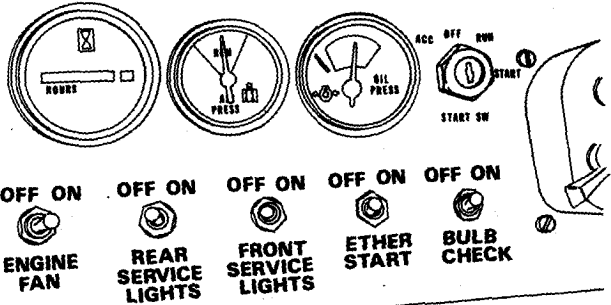
Item No 1	Interval				Item To Be Inspected Procedure: Check and have repaired, filled or adjusted as needed.	Equipment Is NOT READY/AVAILABLE IF:
	B	D	A	W		
6					<p>b. Check wheels for loose or missing mounting bolts.</p> <p>SEAT BELTS</p>  <p>Check that belt is securely mounted, material is not frayed and latch is operable.</p> <p>INSTRUMENT WARNING LIGHTS AND ALARM</p>  <p>a. With fan switch off, engine off, ignition on, press bulb check switch. AU instrument panel lights (except oil pressure, ground driven steering and low air lights) should come on.</p>	<p>One or more bolts missing.</p> <p>Belt not securely mounted, latch inoperable.</p> <p>Any warning light that does not have a gage not functioning.</p>

TA327922

Operator/Crew Preventive Maintenance Checks and Services

NOTE : Within designated interval, these checks are to be performed in the order listed.

B - Before D - During A - After W - Weekly

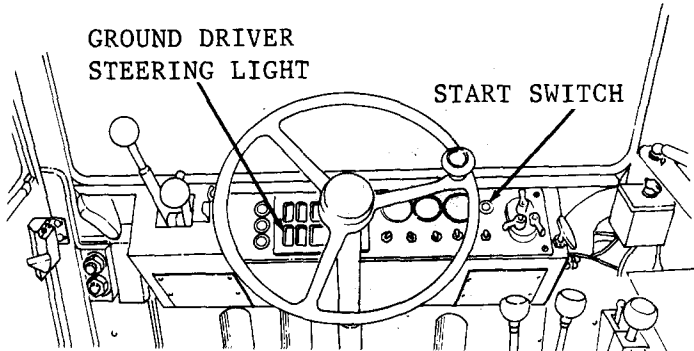
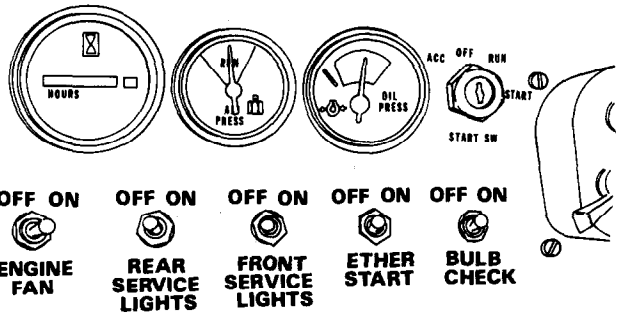
Item No.	Interval				Item To Be Inspected Procedure: Check and have repaired, filled or adjusted as needed.	Equipment Is NOT READY/AVAILABLE IF:
	B	D	A	W		
					 <p>b. With start switch in run position, ground driven steering light should come on.</p> <p>c. With start switch in run position, listen for warning alarm. Sound should remain as long as parking brake is on, or air pressure is low. On S/N 2001 and above, sound also should remain when service brake pressure converter hydraulic pressure is low.</p>  <p>NOTE: Start engine, allow for warm-up, and check that:</p> <p>d. Hourmeter is operating.</p> <p>e. Air pressure gage pointer is in the green range.</p>	<p>Alarm does not sound.</p> <p>Gage pointer is out of green range.</p>

TA327923

Operator/Crew Preventive Maintenance Checks and Services

NOTE : Within designated interval, these checks are to be performed in the order listed.

B - Before D - During A - After W - Weekly

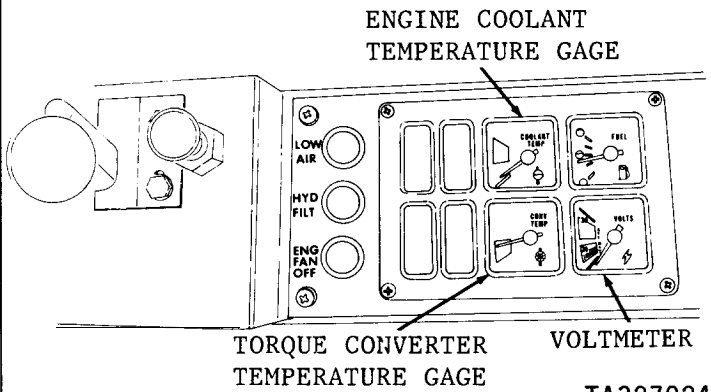
Item No.	Interval				Item To Be Inspected Procedure: Check and have repaired, filled or adjusted as needed.	Equipment Is NOT READY/AVAILABLE IF:
	B	D	A	W		
					<p>f. Engine oil pressure gage pointer is in green area.</p> <div style="text-align: center;">  <p>ENGINE COOLANT TEMPERATURE GAGE</p> <p>TORQUE CONVERTER TEMPERATURE GAGE</p> <p>VOLTMETER</p> <p>TA327924</p> </div>	Gage pointer is in black area.
					<p>g. Voltmeter pointer is in low green area when start switch is on RUN and high green area when engine is running and start switch is on RUN.</p>	Gage pointer is erratic or in black area.
					<p>h. Torque converter temperature gage pointer is in green area.</p>	Gage pointer is in black area.
					<p>i. Engine coolant temperature gage pointer is in green area.</p>	Gage pointer is in red area.
					<p>j. The following warning lights are off:</p> <p>Low air, hydraulic filter, engine fan off, engine oil pressure, engine coolant temperature, torque converter temperature, ground driven steering.</p> <p style="text-align: center;">NOTE</p> <p>If hydraulic filter lights stay on after the oil has warmed, have the reservoir filter serviced.</p>	Any warning light is illuminated.

Operator/Crew Preventive Maintenance Checks and Services

NOTE: Within designated interval, these checks are to be performed in the order listed.

B - Before D - During A - After W - Weekly

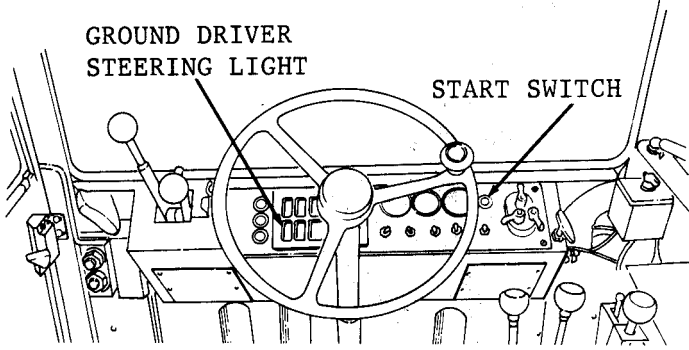
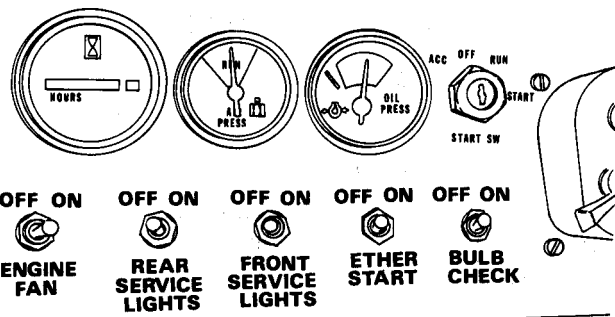
Item No.	Interval				Item To Be Inspected Procedure: Check and have repaired, filled or adjusted as needed.	Equipment Is NOT READY/AVAILABLE IF:
	B	D	A	W		
					 <p>b. With start switch in run position, ground driven steering light should come on.</p> <p>c. With start switch in run position, listen for warning alarm. Sound should remain as long as parking brake is on, or air pressure is low. On S/N 2001 and above, sound also should remain when service brake pressure converter hydraulic pressure is low.</p>  <p>NOTE: Start engine, allow for warm-up, and check that:</p> <p>d. Hourmeter is operating.</p> <p>e. Air pressure gage pointer is in the green range.</p>	<p>Alarm does not sound.</p> <p>Gage pointer is out of green range.</p> <p>TA327923</p>

Operator/Crew Preventive Maintenance Checks and Services

NOTE: Within designated interval, these checks are to be performed in the order listed.

B - Before D - During A - After W - Weekly

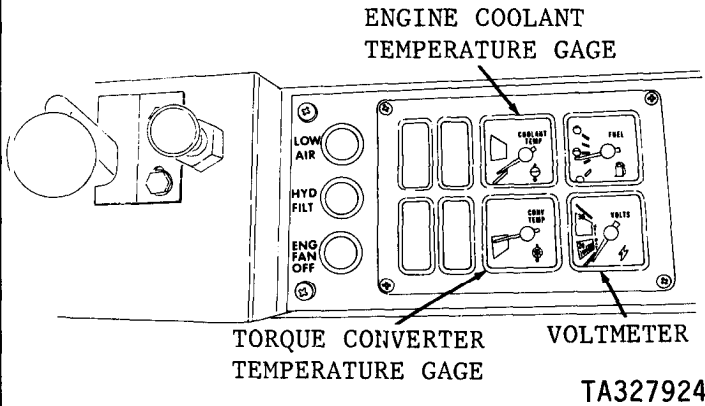
Item No.	Interval				Item To Be Inspected Procedure: Check and have repaired, filled or adjusted as needed.	Equipment Is NOT READY/AVAILABLE IF:
	B	D	A	W		
					<p>f. Engine oil pressure gage pointer is in green area.</p> 	Gage pointer is in black area.
					<p>g. Voltmeter pointer is in low green area when start switch is on RUN and high green area when engine is running and start switch is on RUN.</p> <p>h. Torque converter temperature gage pointer is in green area.</p> <p>i. Engine coolant temperature gage pointer is in green area.</p> <p>j. The following warning lights are off:</p> <p>Low air, hydraulic filter, engine fan off, engine oil pressure, engine coolant temperature, torque converter temperature, ground driven steering.</p> <p>NOTE</p> <p>If hydraulic filter lights stay on after the oil has warmed, have the reservoir filter serviced.</p>	<p>Gage pointer is erratic or in black area.</p> <p>Gage pointer is in black area.</p> <p>Gage pointer is in red area.</p> <p>Any warning light is illuminated.</p>

Operator/Crew Preventive Maintenance Checks and Services

NOTE: Within designated interval, these checks are to be performed in the order listed.

B - Before D - During A - After W - Weekly

Item No.	Interval				Item To Be Inspected Procedure: Check and have repaired, filled or adjusted as needed.	Equipment Is NOT READY/AVAILABLE IF:
	B	D	A	W		
8	●				<p>k. If warning alarm sounds, check if parking brake is applied. Release parking brake. If warning alarm continues to sound, notify organizational maintenance. If alarm sounds only when transmission is in gear, stop vehicle immediately and notify organizational maintenance.</p> <p>LIGHTS</p> <p>Check that all service, drive and blackout lights are working.</p>	Warning alarm continues to sound.
					9	

Operator/Crew Preventive Maintenance Checks and Services

NOTE: Within designated interval, these checks are to be performed in the order listed.

B - Before D - During A - After W - Weekly

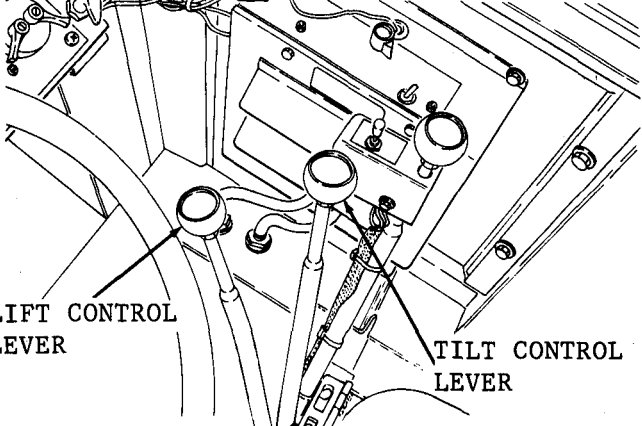
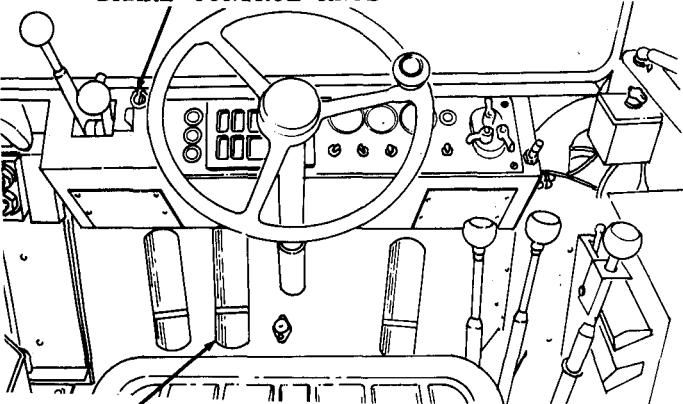
Item No.	Interval				Item To Be Inspected Procedure: Check and have repaired, filled or adjusted as needed.	Equipment Is NOT READY/AVAILABLE IF:
	B	D	A	W		
10		●			<p>LIFT FORK CONTROLS</p>  <p>LIFT CONTROL LEVER</p> <p>TILT CONTROL LEVER</p> <p>Check that lift, tilt, sideshift, and oscillation movement are smooth and immediate.</p>	<p>Any function fails to operate or is erratic.</p>
11				<p>SERVICE BRAKES</p> <p>PARKING/EMERGENCY BRAKE CONTROL KNOB</p>  <p>SERVICE BRAKE</p> <p>Check service brakes for vibration, rubbing, uneven stopping, pulling and unusual noise.</p>	<p>Brakes fade, slip, will not stop or hold vehicle.</p>	

TA327926

Operator/Crew Preventive Maintenance Checks and Services

NOTE: Within designated interval, these checks are to be performed in the order listed.

B - Before D - During A - After W - Weekly

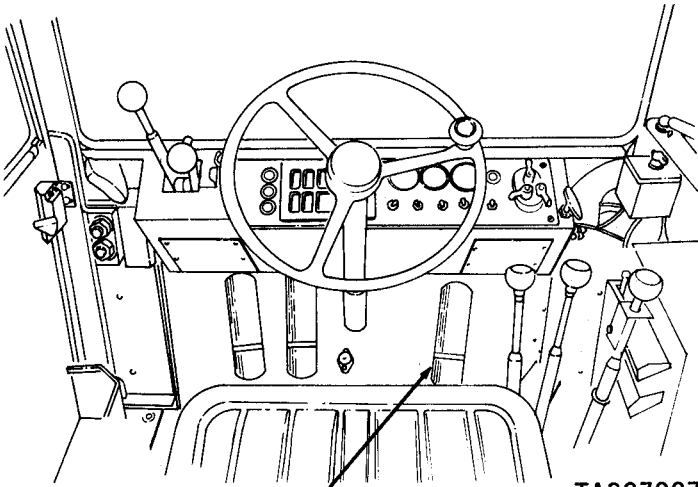
Item No.	Interval				Item To Be Inspected Procedure: Check and have repaired, filled or adjusted as needed.	Equipment Is NOT READY/AVAILABLE IF:
	B	D	A	W		
12		●			<p>PARKING BRAKE</p> <p>Check that parking brake operates properly.</p>	Brake does not hold vehicle.
13					<p>ACCELERATOR</p>  <p>ACCELERATOR TA327927</p> <p>Check that accelerator operates smoothly.</p>	Pedal sticks or binds.
14		●			<p>STEERING WHEEL</p> <p>Check for smooth steering.</p>	Will not steer or has erratic steering.

Operator/Crew Preventive Maintenance Checks and Services

NOTE: Within designated interval, these checks are to be performed in the order listed.

B - Before D - During A - After W - Weekly

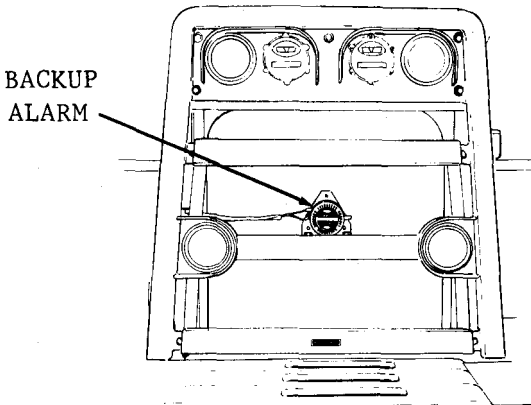
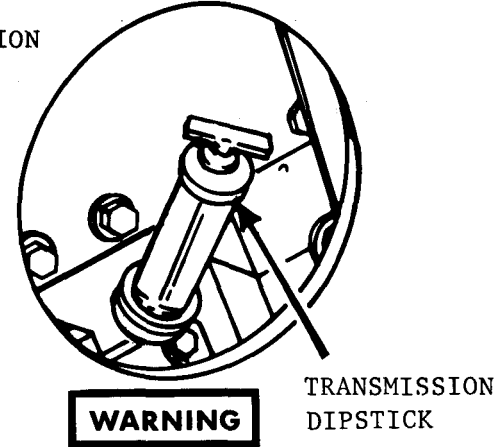
Item No.	Interval				Procedure: Check and have repaired, filled or adjusted as needed.	Equipment Is NOT READY/AVAILABLE IF:
	B	D	A	W		
15					<p>BACKUP ALARM (S/N 2001 AND ABOVE)</p>  <p>Check to be sure the alarm sounds.</p>	
16					<p>TRANSMISSION</p>  <p>TRANSMISSION DIPSTICK</p> <p>WARNING</p> <p>With engine operating at low idle:</p> <p>a. Check level on dipstick, maintain fluid level between ADD and FULL mark on dipstick. Refer to LO 10-3930-643-12.</p>	

TA327928

Operator/Crew Preventive Maintenance Checks and Services

NOTE : Within designated interval, these checks are to be performed in the order listed.

B - Before D - During A - After W - Weekly

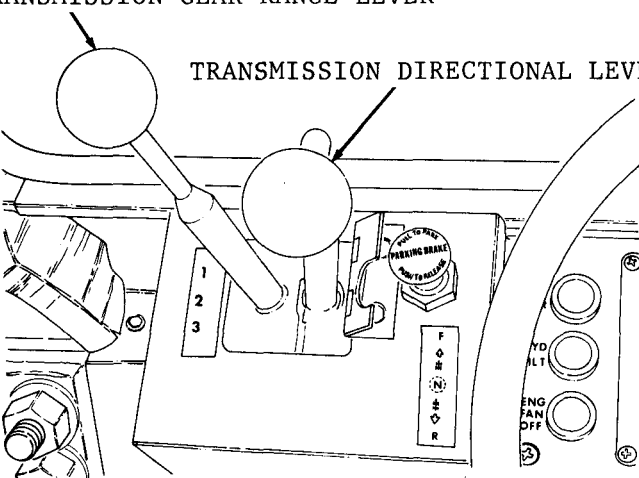
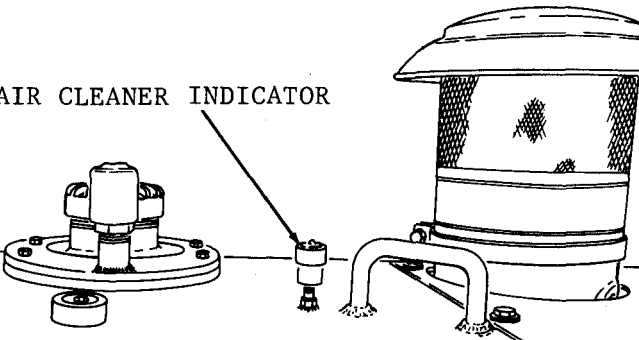
Item No.	Interval				Item To Be Inspected Procedure: Check and have repaired, filled or adjusted as needed.	Equipment Is NOT READY/AVAILABLE IF:
	B	D	A	W		
17					<p>TRANSMISSION GEAR RANGE LEVER</p>  <p>TRANSMISSION DIRECTIONAL LEVER</p> <p>b. Check that transmission shift levers operate smoothly.</p>	Levers stick, bind, or do not operate.
					<p>AIR CLEANER</p> <p>AIR CLEANER INDICATOR</p>  <p>With engine running, check air cleaner indicator. Have serviced if red band in indicator window is fully exposed.</p>	

TA327929

Operator/Crew Preventive Maintenance Checks and Services

NOTE: Within designated interval, these checks are to be performed in the order listed.

B - Before D - During A - After W - Weekly

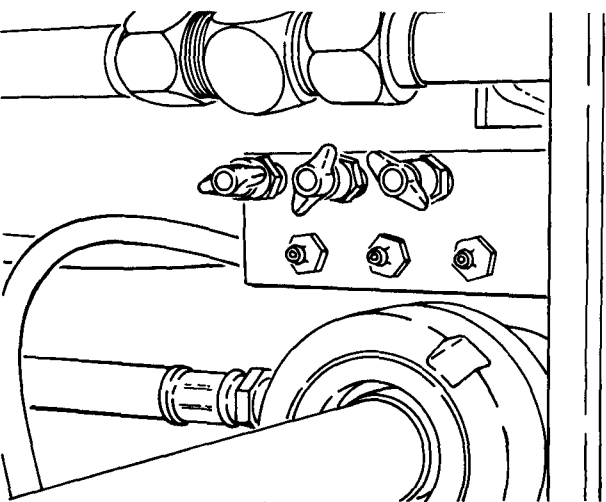
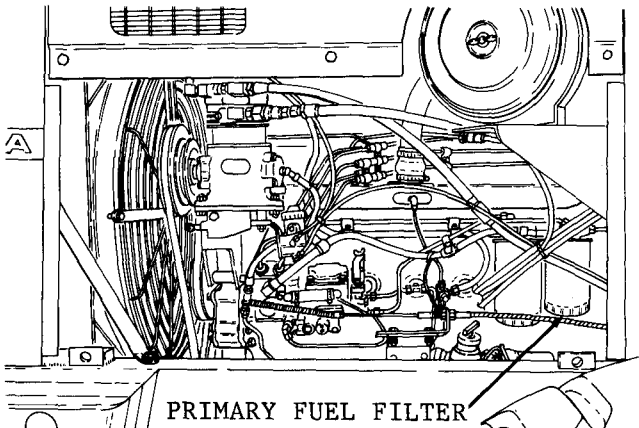
Item No.	Interval				Item To Be Inspected Procedure: Check and have repaired, filled or adjusted as needed.	Equipment Is NOT READY/AVAILABLE IF:
	B	D	A	W		
18					<p>AIR TANK VALVES</p>  <p>● Open air tank valves only long enough to remove any accumulated moisture in the system.</p>	
19					<p>PRIMARY FUEL FILTER (S/N 2001 AND ABOVE)</p>  <p>● Drain water from primary fuel filter.</p>	

TA327930

Operator/Crew Preventive Maintenance Checks and Services

NOTE : Within designated interval, these checks are to be performed in the order listed.

B - Before D - During A - After W - Weekly

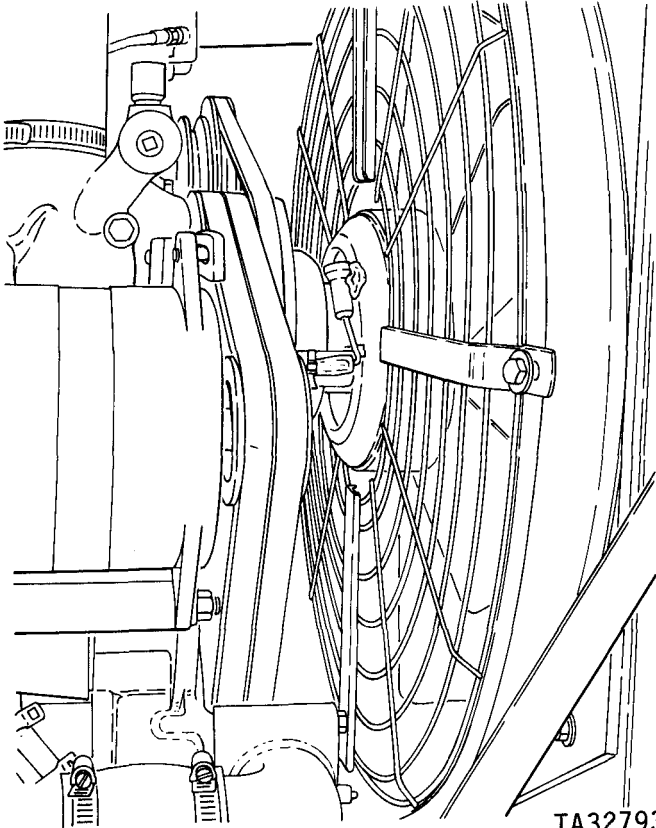
Item No.	Interval				Item To Be Inspected Procedure: Check and have repaired, filled or adjusted as needed.	Equipment Is Not READY/AVAILABLE IF:
	B	D	A	W		
20					<p>FAN AND DRIVE BELTS</p>  <p>TA327931</p> <ul style="list-style-type: none"> ● a. Check belts for frayed or damaged condition. ● b. Check fan for bent or damaged blades. 	<p>Belts are damaged or missing.</p> <p>Blades are bent or damaged</p>

Operator/Crew Preventive Maintenance Checks and Services

NOTE : Within designated interval, these checks are to be performed in the order listed.

B - Before D - During A - After W - Weekly

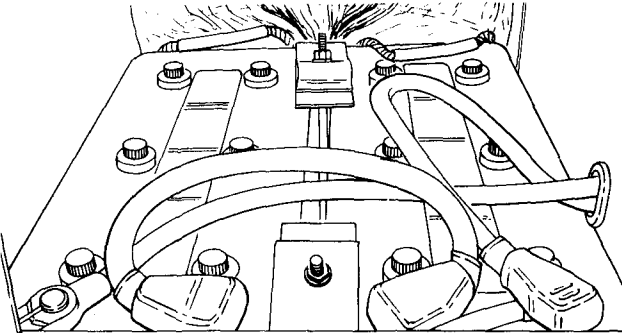
Item No.	Interval				Item To Be Inspected Procedure: Check and have repaired, filled or adjusted as needed.	Equipment Is NOT READY/AVAILABLE IF:
	B	D	A	W		
21					<p>BATTERIES</p>  <p style="text-align: right;">TA327932</p> <p style="text-align: center;">WARNING</p> <p>Sulfuric acid contained in batteries can cause severe chemical burns if not handled properly.</p> <p style="text-align: center;">WARNING</p> <p>Do not smoke or allow any flame or spark in the vicinity while checking the battery. The battery generates hydrogen, a highly explosive gas.</p> <p>Check electrolyte level. Refer to TM 9-6120-200-14. If level of electrolyte is below the top of the battery plates, notify organizational maintenance.</p> <p>b. Check battery and battery box for corrosion and obvious damage.</p>	Battery cracked, missing or engine will not crank.

Section III. OPERATION UNDER USUAL CONDITIONS

WARNING

Before starting engine and operating forklift, be thoroughly familiar with the information in this manual. Review all warnings and safety precautions.

2-19. INITIAL ADJUSTMENTS, DAILY CHECKS, AND SELF TEST.

- a. Lubricate. Refer to LO 10-3930-643-12.
- b. Perform Before (B) PMCS. Refer to paragraph 2-18.
- c. Mounting and Dismounting.

(1) Use steps and grab irons when mounting or dismounting the forklift.

(2) Face the forklift when mounting or dismounting.

(3) Do not use the steering wheel as a hand hold. The forklift could articulate if running.

(4) Do not jump off the forklift.

d. Adjust the seat. Pull the adjust lever back and adjust forward or rearward as desired. Do not adjust the seat while the forklift is in motion.

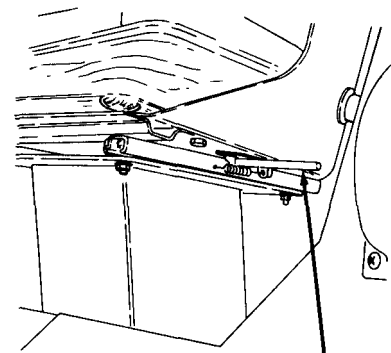

ADJUSTMENT LEVER

WARNING

Seat belt must be fastened at all times during operation of the forklift.

e. Fasten and Adjust the Seat Belt.

(1) Lengthen. Hold the single strap and pull the slide (1) toward the buckle (2). Adjust the buckle (2) to the full extension.

(2) Shorten. Hold the slide (1) and pull the bottom of the loop toward the buckle (2). Adjust the buckle (2) to the full extension.

Legend

1. Slide
2. Buckle

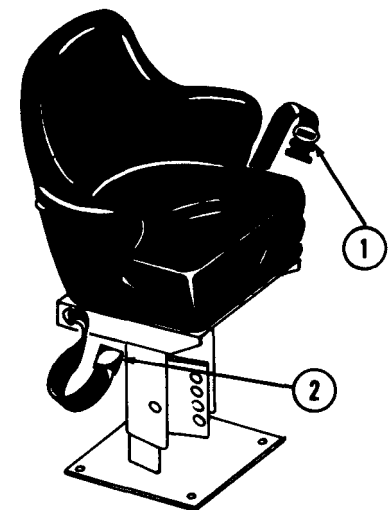

2-20. OPERATING PROCEDURES.

a. Starting the Engine.

NOTE

Check log book to determine period of non-operation. If engine has been idle for 30 days or more the turbo-charger must be primed before starting engine. Notify organizational maintenance.

(1) Before entering cab, turn the Master Disconnect switch ON. Do not use foot.

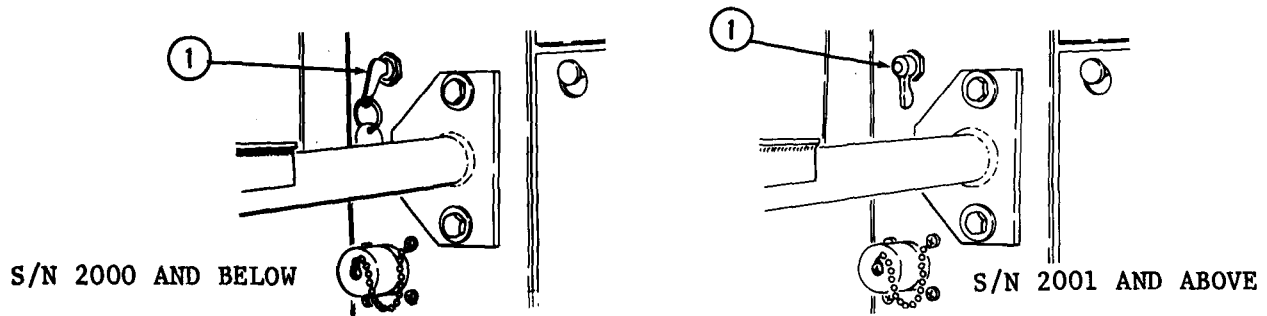

WARNING

ACCIDENTAL HAZARD

To prevent accidental movement of the forklift, apply parking/emergency brake movement and place transmission directional lever in lock position before starting engine.

(2) Apply the parking brake and place the transmission directional lever in neutral.

(3) Depress the accelerator to the one-half engine speed position for temperatures above +50 degrees F or to the full speed position for temperatures below +50 degrees F.

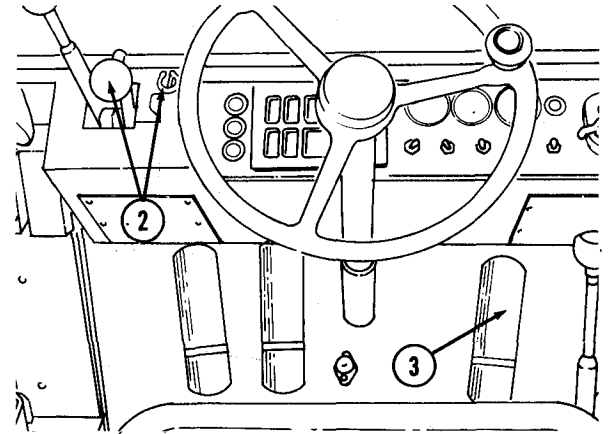
**CAUTION**

After 30 seconds of cranking, allow two minutes for the starting motor to cool.

CAUTION

If the engine oil pressure gage doesn't register within 10 seconds, stop the engine by turning the starting switch to OFF. Notify organizational maintenance.

(4) Turn the starting switch to the START position, and release it the instant the engine starts.

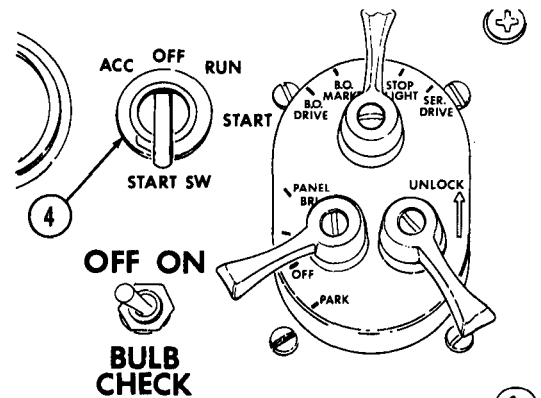
**CAUTION**

Engine fan must be operating when engine is running or engine will overheat. Check engine fan switch to make sure it is on.

(5) Reduce engine speed and keep the engine at low idle, until the systems are warm.

2-20. OPERATING PROCEDURES.-Continued

b. Starting Aids.

(1) Winter oils. To determine the oil for winter use, refer to LUBRICATION SPECIFICATIONS in the LUBE ORDER. Use the recommended weight oil for the temperature range indicated. For other than temperatures shown, see your supervisor or organizational maintenance. Refer to LO 10-3930-643-12.

(2) Ether starting aid.



TOXIC/FLAMMABLE

Ether is toxic and flammable. Use only in well ventilated areas. Avoid contact with eyes, skin and clothes. Do not use ether or discard ether container near an open flame, sparks or heat. Failure to follow these instructions could result in SEVERE INJURY. If injured seek medical attention immediately.

Excessive use of ether will cause piston and ring damage. Use it sparingly and only for starting purposes in temperatures below freezing.

Using ether injector:

- (a) Turn the starting switch to the RUN position.
- (b) Depress accelerator to FULL SPEED position.
- (c) Move ether injector switch to ON position, and hold two to three seconds, filling ether valve chamber with a measured amount of ether.
- (d) Turn starting switch to the START position.

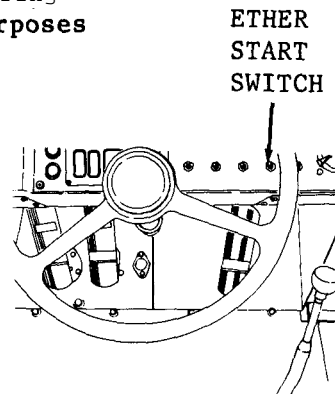

TA327936

NOTE

In extreme cold, if engine fails to start after 30 seconds of cranking, it may be necessary to repeat this procedure. Wait two or three minutes to allow starting motor to cool before starting again. S/N 2001 and above lever type starting switch, must be returned to the OFF position before repeating this procedure. If engine fails to start after second ether injection, refer to paragraph 3-5, troubleshooting and/or organizational maintenance, as required.

(3) Slave starting the engine. Contact organizational maintenance if required.

2-20. OPERATING PROCEDURES.-Continued

d. After Starting.

(1) Perform during (D) PMCS. Refer to paragraph 2-18.

(2) Operate the engine at low idle until the hydraulic oil is warm. When the temperature is below 35 degrees, move all hydraulic controls slowly to warm them up. Move each cylinder several times to warm it.

(3) Test the hydraulic controls. Allow extra warm-up time if controls are sluggish.

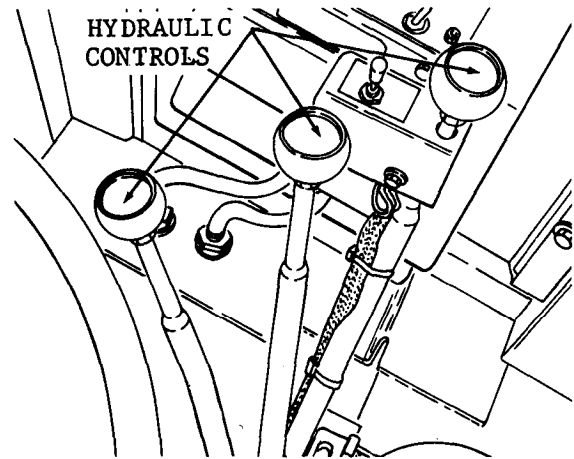

TA327937

d. Moving the Forklift. Be sure your seat belt is fastened. Before moving the forklift or operating the boom or forks, be sure all personnel are clear of the area. Transmission directional lever lock must be moved to the unlock position in order to shift the transmission directional lever.

2-20. OPERATING PROCEDURES.-Continued

The air pressure gage must be in the green range. If it is not, stop the engine, apply parking/emergency brake and lock transmission directional lever. Notify organizational maintenance of the problem.

- (1) Depress the brake pedal (1).

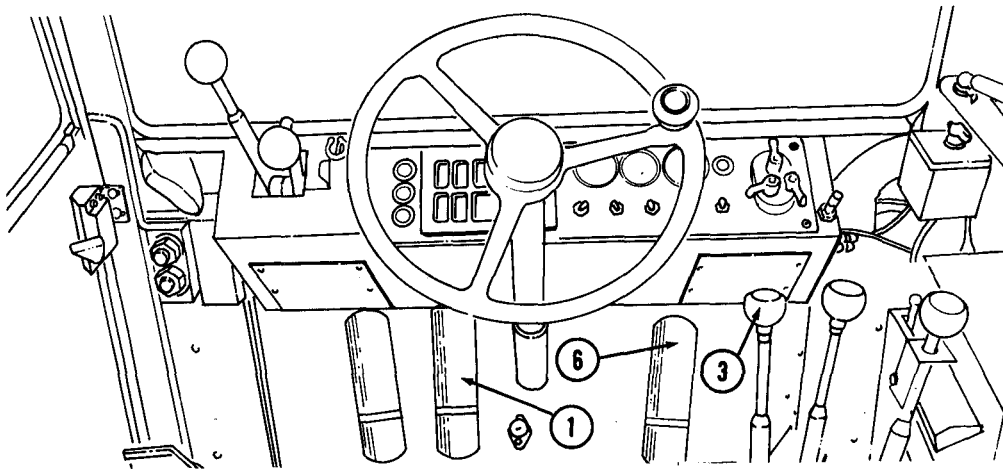

Legend

- 1. Brake pedal
- 2. Parking/emergency brake
- 3. Lift control lever
- 4. Transmission directional lever
- 5. Transmission gear range lever
- 6. Accelerator

CAUTION

Brake damage can occur if the machine is moved with the brake applied.

- (2) Release the parking/emergency brake (2).

(3) Partially accelerate (6) the engine and raise the forks (3) enough to clear the ground. Release the accelerator pedal (6).

(4) Place the transmission direction lever (4) in the desired position.

(5) Place the gear range lever (5) in the first gear position.

(6) Release the brake pedal (1) and gradually depress the accelerator (6).

- (7) Select desired working speed.

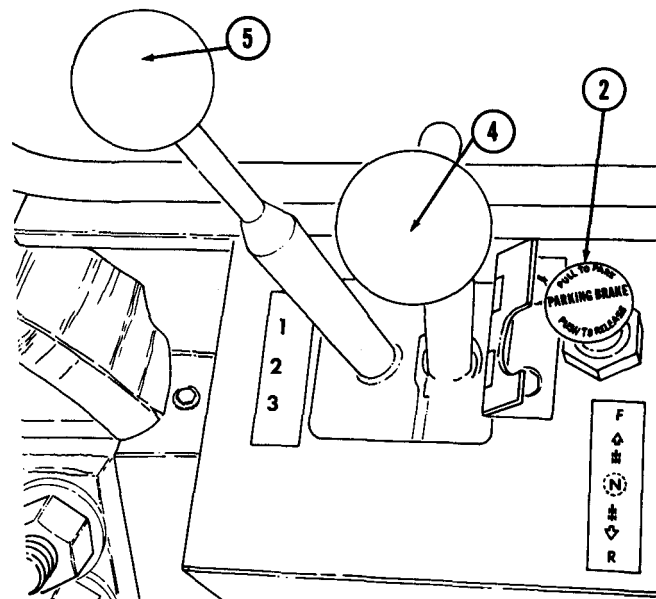

TA327938

2-20. OPERATING PROCEDURES.-Continued

e. Shifting Transmission Gears. The transmission has three forward gear ranges, three reverse gear ranges, and neutral, which are manually selected with the transmission gear range and direction levers, "1" (first gear) is the lowest and main working gear range. "2" (second gear) can be used for working and rearing the machine. "3" (third gear) is used to road the machine for longer distances at the maximum machine speeds. The direction lever "N" (neutral) position has a neutral start safety switch incorporated in it. The direction lever must be in "N" before the engine can be started. "R" (reverse) also has "1" (first), "2" (second) and "3" (third) gear ranges.

The gear range or direction can be changed only under the following condition:

WARNING

LOSS OF CONTROL

When traveling downhill never shift transmission into neutral. You could lose control of the forklift and be seriously injured.

CAUTION

Never shift transmission into neutral when traveling downhill. This could cause loss of machine control or damage to the drive train upon shifting back into gear.

(1) Down-shifting. A down-shift from "3" to "2" or "2" to "1" or "3" to "1" can be made at any time to maintain an efficient engine speed.

(2) Up-shifting. An up-shift from "1" to "2" or "2" to "3" or "1" to "3" can be made at any time. The most efficient use of each gear range is achieved when maximum engine rpm is reached in the gear range before an up-shift is made.

(3) Direction changes. Forklift must come to a complete stop before changing forward or reverse direction.

f. Stopping the Forklift.

(1) Apply the service brakes to stop the forklift.

(a) Fully release the accelerator pedal.

WARNING

Do not use the brake and transmission disconnect pedal when traveling at a fast speed or when going downhill.

(b) Apply the service brake and transmission disconnect pedals until the vehicle comes to a complete halt.

2-20. OPERATING PROCEDURES.-Continued

WARNING

Do not fan the brakes by repeatedly depressing and releasing the brake pedal. This can reduce air pressure too low for braking.

- (c) Move the transmission directional lever to the neutral position.
- (d) Lower forks to the ground.
- (e) Apply parking brake.

WARNING

If emergency brake must be used to stop forklift, prepare for sudden stop and brace yourself to prevent serious head, neck, and back injuries.

(2) If the service brakes fail, the vehicle can be stopped by applying the parking/emergency brake.

g. Steering. The machine is articulated and steering is accomplished by hydraulic power, which pivots the main frames at the center hinge. Turn the steering wheel until reaching the desired angle of turn. Hydraulic power holds the angle of turn until the steering wheel is again turned.

2-20. OPERATING PROCEDURES.-Continued

h. Fork Carriage Operation.

CAUTION

Do not hold 2nd control lever in any position except HOLD, for an extended length of time. Failure to follow this instruction will damage the hydraulic system and affect forklift performance.

(1) Lift control lever. First lever to the right of the operator's seat. It has three control positions: RAISE, HOLD, and LOWER.

(a) RAISE. Pull the lever back until desired height is reached. Return to HOLD is automatic, when the lever is released.

(b) HOLD. Lever automatically returns to HOLD when released. Forks remain at the height allowed, when the lever is placed in HOLD.

(c) LOWER. Push the lever forward until desired height is reached. Return to HOLD is automatic, when the lever is released.

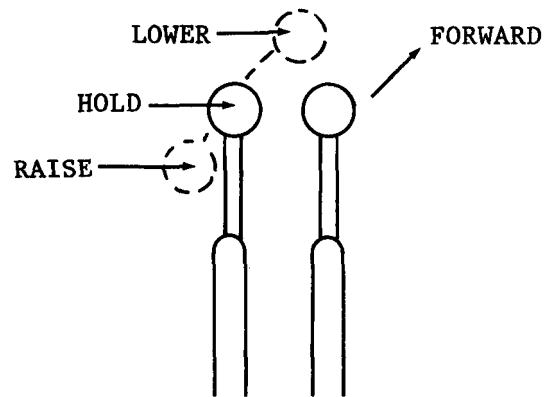

(2) Tilt control lever. Second lever to the right of the operator's seat. It has three control positions: TILT BACK, HOLD, and TILT FORWARD.

(a) TILT BACK. Pull the lever back until the desired upward tilt angle is reached. Return to HOLD is automatic, when the lever is released.

(b) HOLD. Lever automatically returns to HOLD when released. Forks remain stationary at angle attained, when the lever is placed in HOLD.

(c) TILT FORWARD. Push the lever forward until the desired downward tilt angle is reached. Return to HOLD is automatic, when the lever is released.

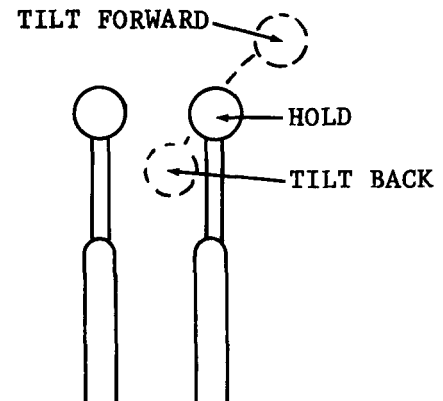

2-20. OPERATING PROCEDURES.-Continued

h. Fork Carriage Operation.-Continued

(3) Sideshift, oscillate and fork positioner control lever. Third lever to the right of the operator's seat. Together with the attached mode selector switch, it has nine fork control positions: FORKS APART, HOLD, FORKS TOGETHER, OSCILLATE CARRIAGE LEFT SIDE DOWN, HOLD, OSCILLATE CARRIAGE RIGHT SIDE DOWN, CARRIAGE SIDESHIFT LEFT, HOLD and CARRIAGE SIDESHIFT RIGHT.

(a) Mode selector switch forward. Lift up on mode selector switch cap and push switch forward.

1 FORKS TOGETHER. Pull lever back to move forks toward each other. Return of the lever to HOLD is automatic, when the lever is released.

2 HOLD. Lever automatically returns to HOLD when released. Forks remain stationary at spacing attained, when lever is placed in HOLD.

3 FORKS APART. Push lever forward to move forks away from each other. Return of the lever to HOLD is automatic, when lever is released.

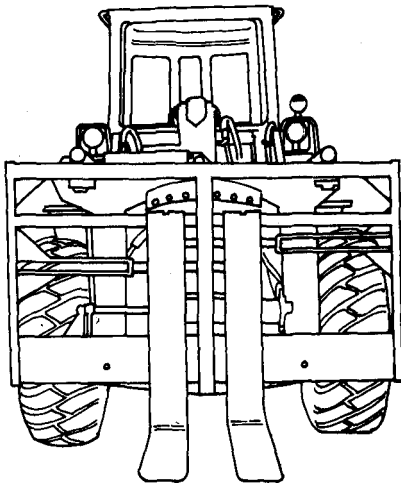
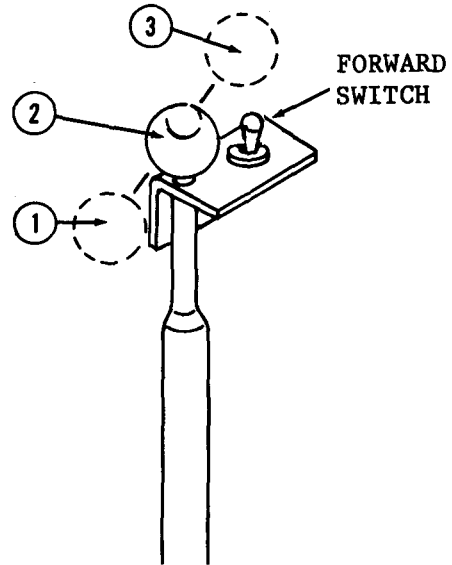

FORKS TOGETHER

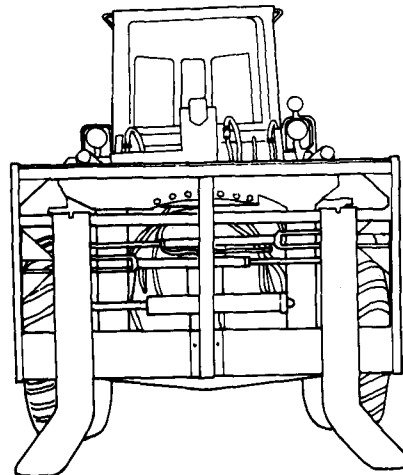

FORKS APART

TA327940

2-20. OPERATING PROCEDURES.-Continued

h. Fork Carriage Operation.-Continued

(b) Mode selector switch in center position.

1 OSCILLATE RIGHT - Pull lever back to rotate carriage in a lowering of the right fork and raising the left fork direction. Return of the lever to HOLD is automatic, when lever is released.

2 HOLD - Lever automatically returns to HOLD when released. Forks remain stationary at position attained, when lever is placed in HOLD.

3 OSCILLATE LEFT - Push lever forward to rotate carriage in a lowering of the left fork and raising of the right fork direction. Return of the lever to HOLD is automatic, when lever is released.

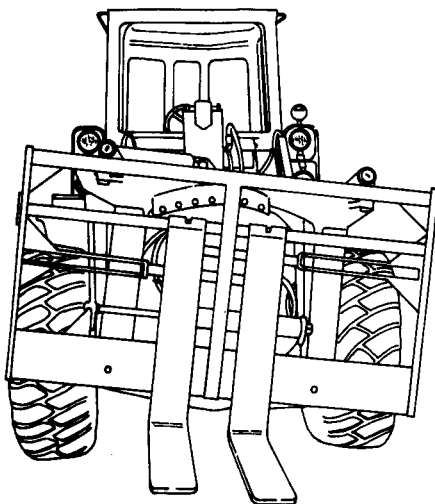
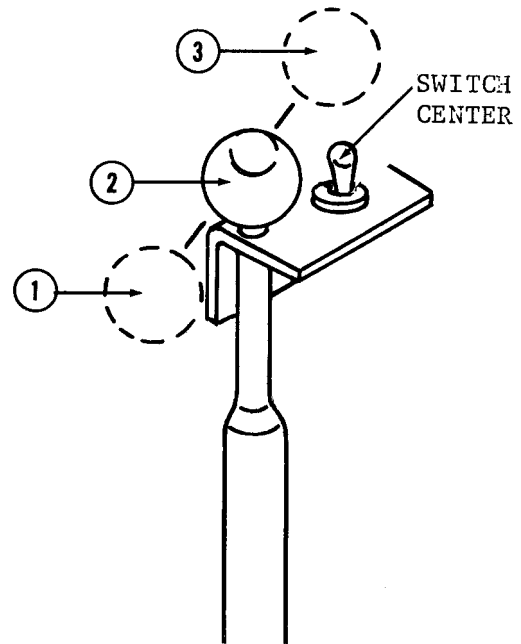

OSCILLATE LEFT SIDE DOWN

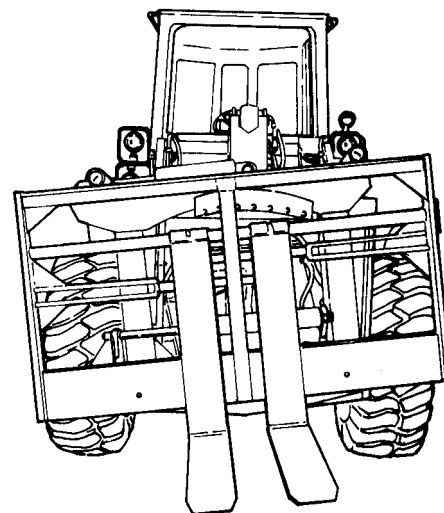

OSCILLATE RIGHT SIDE DOWN

2-20. OPERATING PROCEDURES.-Continued

h. Fork Carriage Operation.-Continued

(c) Mode selector switch back.

1 SIDESHIFT RIGHT - Pull lever back to move the fork carriage to the right. Return of the lever to HOLD is automatic, when the lever is released.

2 HOLD - Lever automatically returns to HOLD when released. Forks remain stationary at position attained, when lever is placed in HOLD.

3 SIDESHIFT LEFT - Push lever forward to move the fork carriage to the left. Return of the lever to HOLD is automatic, when the lever is released.

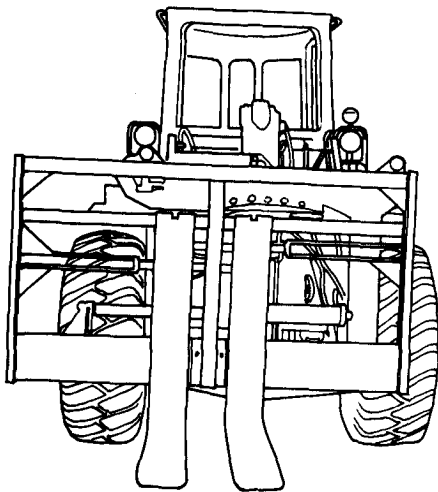
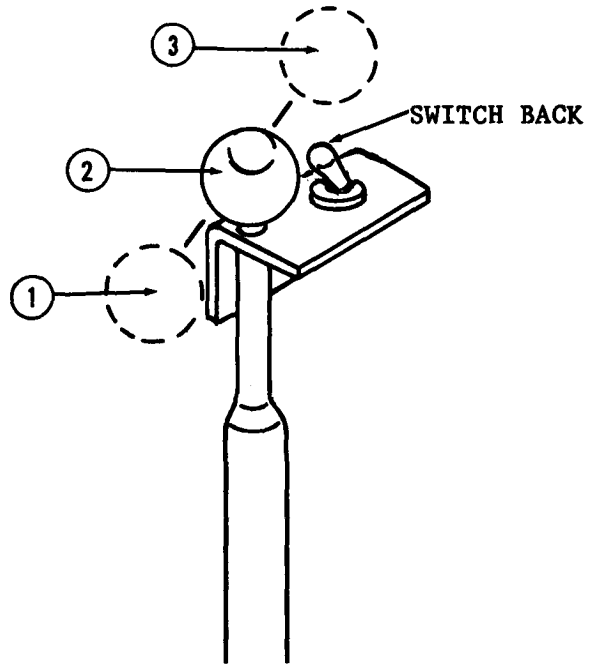

SIDESHIFT RIGHT

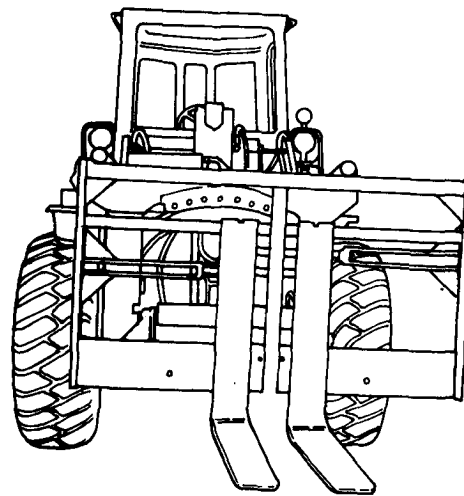

SIDESHIFT LEFT

2-20. OPERATING PROCEDURES.-Continued

i. Parking the forklift.

- (1) Move forklift to a safe, level location.
- (2) Lower forks to the ground.
- (3) Move the lock over the transmission direction lever.
- (4) Stop engine according to procedure in paragraph k.

j. Stopping the Engine.

CAUTION

Stopping the engine immediately after forklift has been under a load could result in overheating and accelerated wear. To prevent mechanical problems, use the following procedure to allow engine to cool safely.

- (1) Park the forklift and operate the engine at low idle for five minutes.
- (2) Turn the starting switch to the OFF position.

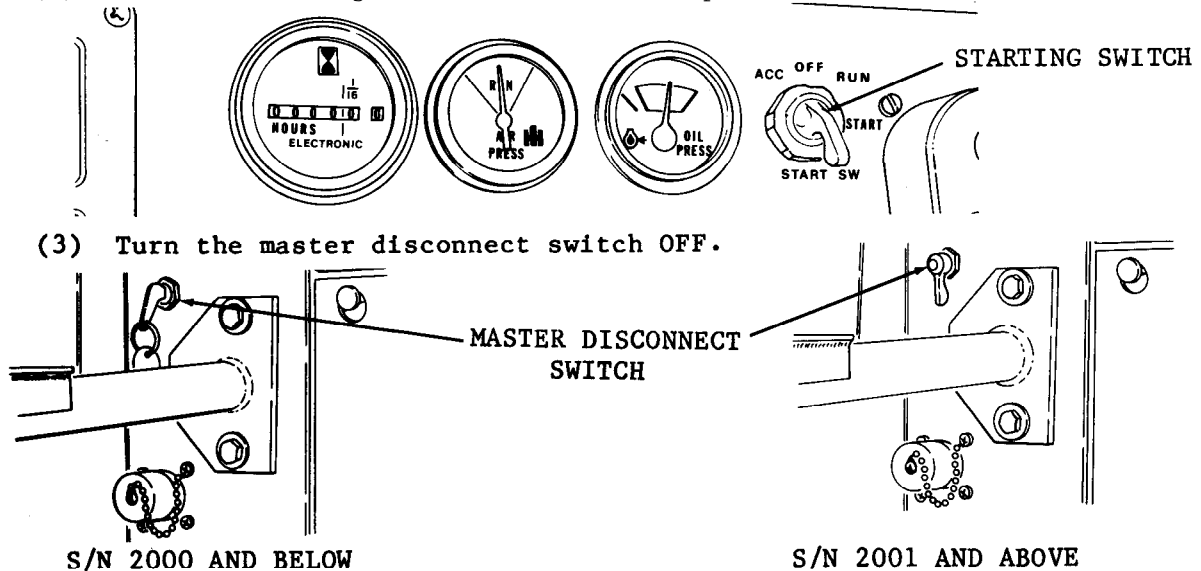

- (3) Turn the master disconnect switch OFF.
- (4) Perform your After (A) PMCS. Refer to paragraph 2-18.
- (5) When leaving the forklift:
 - (a) Lock the ignition and master disconnect switch and remove keys. S/N 2000 and below.
 - (b) Close and lock the cab door and windows. S/N 2001 and above.

NOTE

Before any extended shutdown period, be sure fuel tank is filled to prevent condensation.

2-21. PREPARATION FOR MOVEMENT. Contact organizational maintenance.

2-22. OPERATING INSTRUCTIONS ON DECALS AND INSTRUCTION PLATES.

a. Exterior and Interior Right Side. S/N 2000 and below.

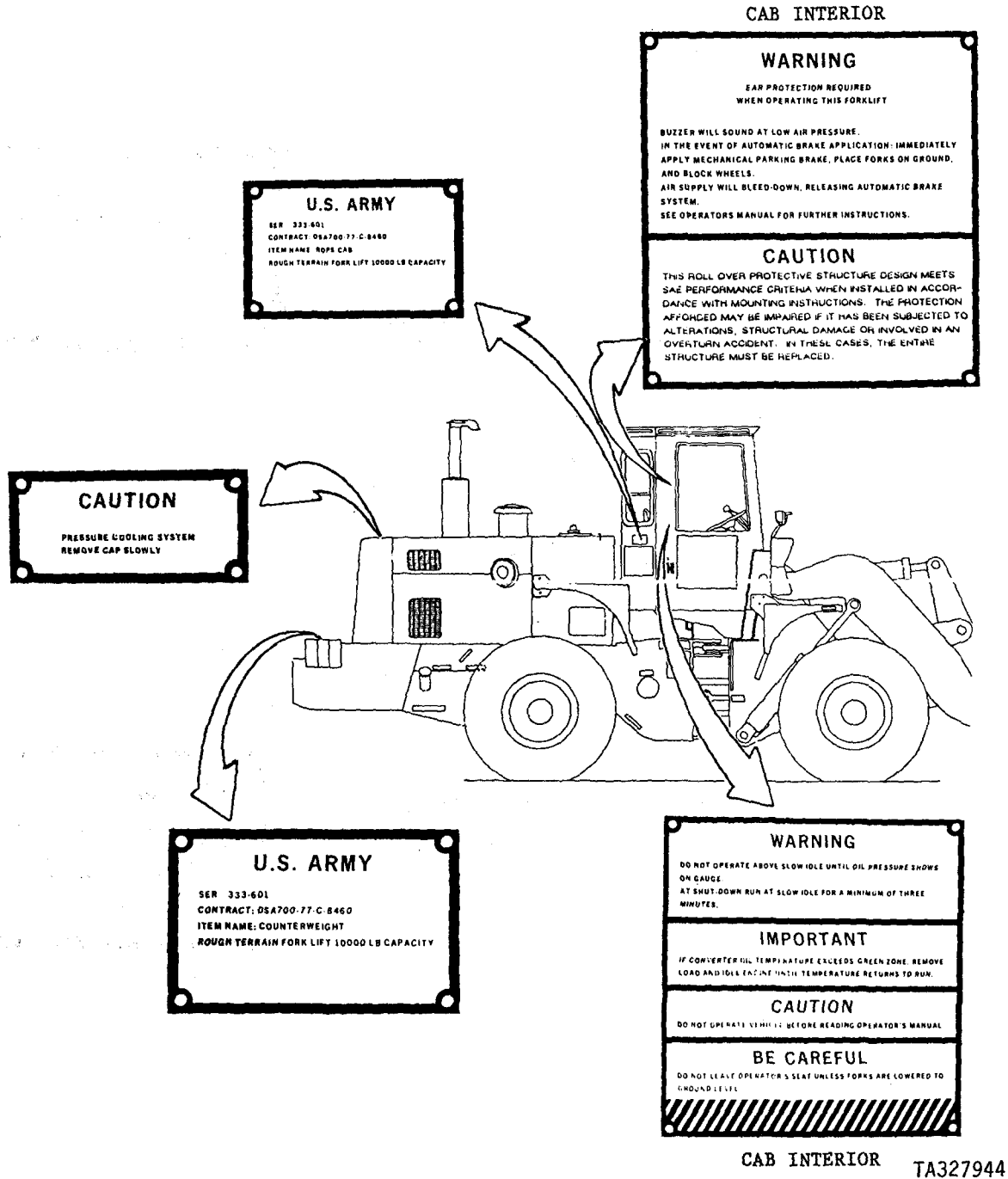

2-22. OPERATING INSTRUCTIONS ON DECALS AND INSTRUCTION PLATES.-Continued

a. Exterior and Interior Right Side. S/N 2000 and below.

CAUTION
HYDRAULIC RESERVOIR IS PRESSURIZED.
REMOVE FILLER CAP SLOWLY TO
RELIEVE PRESSURE

CAB INTERIOR

CAUTION
FAN AND RELATED COMPONENTS
WILL BE DAMAGED AND PRESENT
A SAFETY HAZARD IF FAN IS
OPERATING OR ENGAGED WHEN
WATER LEVEL IS IN FAN SWEEP.
ENGAGE FAN ONLY AT LOW IDLE
ENGINE SPEED

U.S. ARMY
10,000 ROUGH TERRAIN FORK LIFT
MODEL M10A CONTR D6A780-77-C-8460
SER 333-001 CAP 10,000
SHIP WT 36,500 DATE MFD
HGT: 128 W: 100.5 LG: 342.5
ENG SER CUBE: 2950 FT
NSN
PAY LINE GROUP, LIBERTYVILLE ILL

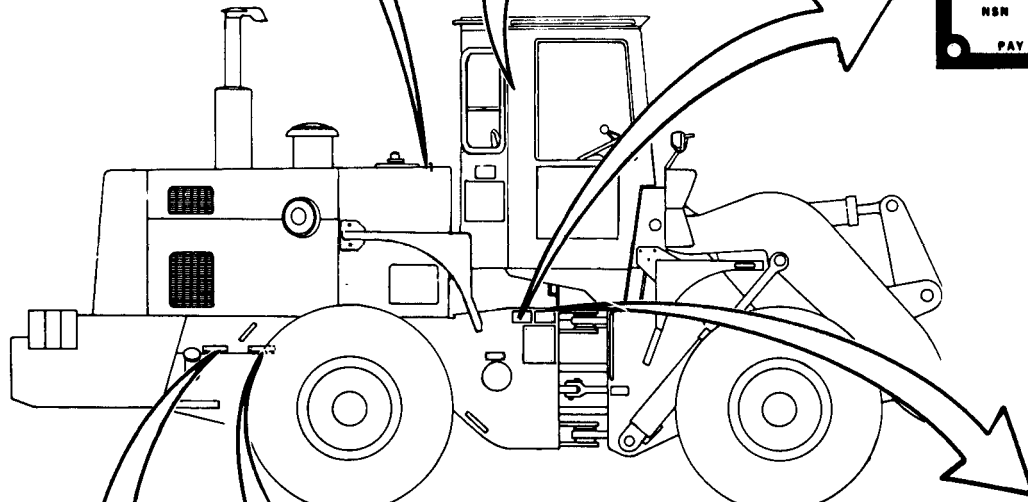

ENGINE OIL DRAIN

DANGER
NO CLEARANCE IN THIS AREA WHEN VEHICLE
IS OPERATING.
LADDERS OR STEPS ARE PLACED HERE FOR
ENTERING, LEAVING OR SERVICING VEHICLE.
STANDING ON THEM WHEN VEHICLE IS BEING
OPERATED IS DANGEROUS.

DIESEL FUEL

TA327945

2-22. OPERATING INSTRUCTIONS ON DECALS AND INSTRUCTION PLATES.-Continued

a. Exterior and Interior Right Side. S/N 2000 and below.

M10A PAYLOADER		LUBRICATION CHART		REMARKS	
LUBRICATION INTERVAL	ITEM NO	POINT OF LUBRICATION OR REFILL	LUBRICANT	LUBE SPEC	
EVERY 100 HOURS	1	LOADING SYSTEM DRUM & WINDSOR ABOUT 32 F BELOW 32 F	CRANKING SYSTEM CONDENSER SAE 30	SAE 30	
	11	DRIVE TORNAL OIL 32 F TO 70 F	SAE 10W	SAE 10W	
	4	HYDRAULIC SYSTEM 32 F TO 70 F	SAE 10W	SAE 10W	
	5	TRANSMISSION ABOUT 70 F	SAE 30	SAE 30	
EVERY 50 HOURS	10	FUEL SYSTEM DIESEL WINDSOR SERVICE ABOVE 42 F BELOW 40 F	GRADE #2	ASTM D 975	
	13	DRIVE TORNAL OIL 32 F TO 70 F	SAE 10W	SAE 10W	
	14	DRIVE TORNAL OIL 32 F TO 70 F	SAE 10W	SAE 10W	
	15	DRIVE TORNAL OIL 32 F TO 70 F	SAE 10W	SAE 10W	
EVERY 20 HOURS	20	DRUM LUB 3	MULTI PURPOSE	251 HELP OR SUPER GRADE	
	16	FORK LUB 3	MULTI PURPOSE	251 HELP OR SUPER GRADE	
	17	WHEEL CHUCKLE 2	MULTI PURPOSE	251 HELP OR SUPER GRADE	
	18	WHEEL CHUCKLE 2	MULTI PURPOSE	251 HELP OR SUPER GRADE	
EVERY 10 HOURS	7	DRIVE SHAFTS 2	SAE 30	SAE 30	
	8	DRIVE SHAFTS 2	SAE 30	SAE 30	
	9	DRIVE SHAFTS 2	SAE 30	SAE 30	
	19	STEERING GEAR	SAE 30	SAE 30	
NO HOUSING	21	DRIVE SHAFTS 2	SAE 30	SAE 30	
	22	DRIVE SHAFTS 2	SAE 30	SAE 30	
	23	DRIVE SHAFTS 2	SAE 30	SAE 30	
	24	DRIVE SHAFTS 2	SAE 30	SAE 30	

CAB INTERIOR

WARRANTY INFORMATION
 Vehicle warranty is for 18 months or 1500 operating hours whichever occurs first.
 Failed components will be repaired or replaced if attributable to defective material or workmanship.
 For warranty implementation contact:
 Pay Line Group
 Warranty Administration
 Schiller Park, Illinois 60172
 and provide: Contract no., Model no. and Serial no.

RADIATOR DRAIN

CHECK WITH ENGINE AT IDLE AND TRANSMISSION IN NEUTRAL. OIL TEMPERATURE 150° TO 200° USE TRANSMISSION FLUID PER MIL-L-2104C

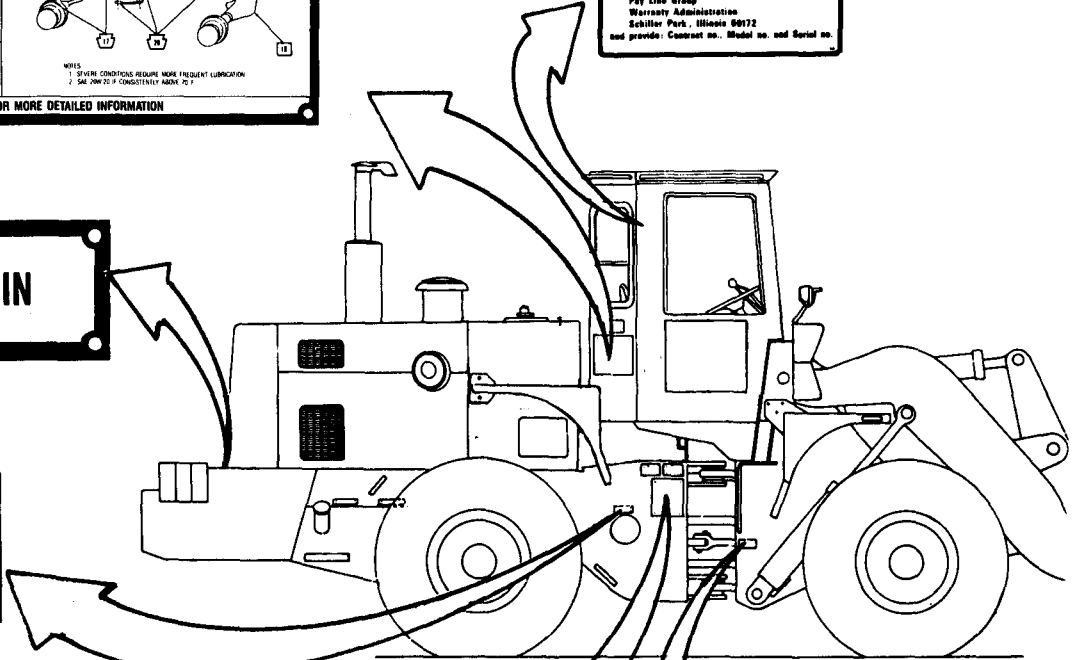

TIE DOWN DATA FOR TRUCK, LIFT, FORK, ARTICULATED FRAME 10,000 LB CAPACITY DED 4x4

TYPICAL FREIGHT CAR TIE DOWN FOR TRUCK TRANSPORT. WHEEL BLOCKS ARE NOT REQUIRED FOR AIR TRANSPORT. ① CAB, ② COUNTERWEIGHTS, ③ MUFFLER & ④ FORKS MUST BE REMOVED. TIE DOWN CABLE TO BE 3/4 DIA IMPROVED PLOW STEEL

CAUTION
 LOCK ARTICULATION BEFORE LIFTING

IMPORTANT
 DRAIN MOISTURE FROM RESERVOIR DAILY.

2-22. OPERATING INSTRUCTIONS ON DECALS AND INSTRUCTION PLATES.-Continued

b. Exterior and Interior Left Side. S/N 2000 and below.

**CAB INTERIOR,
CONTROL PANEL**

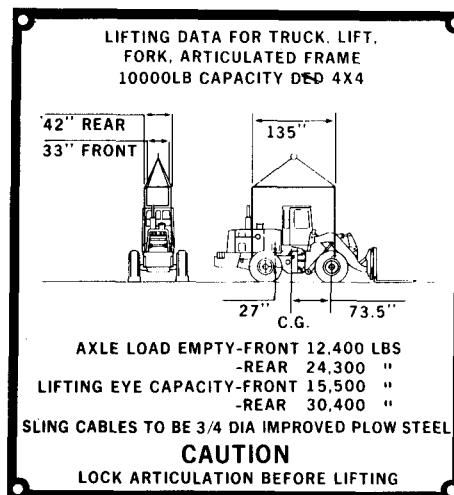
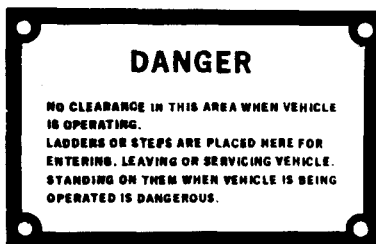
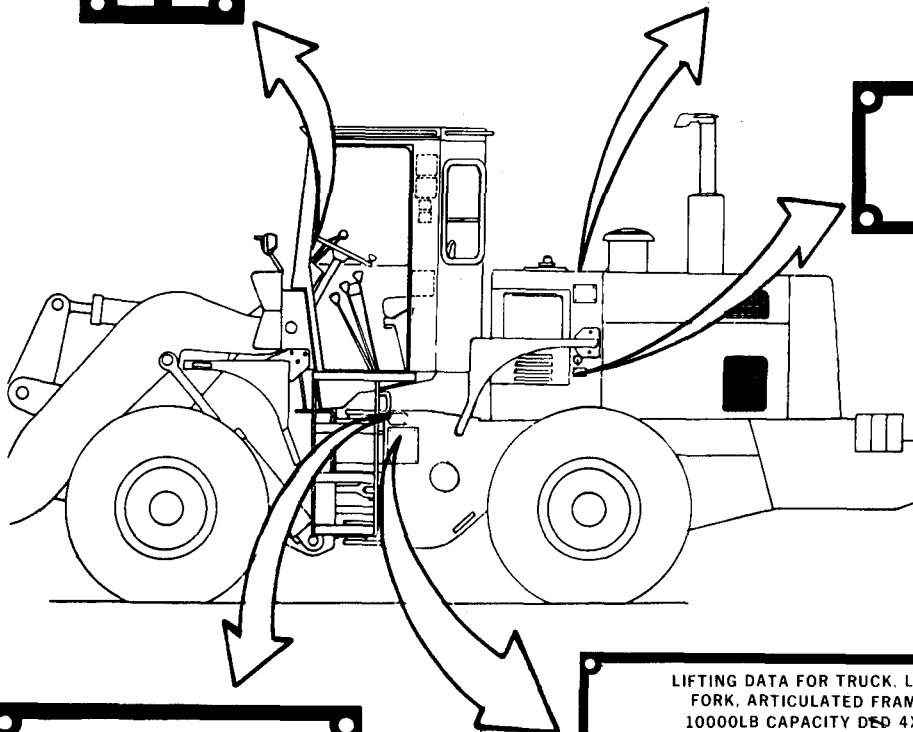
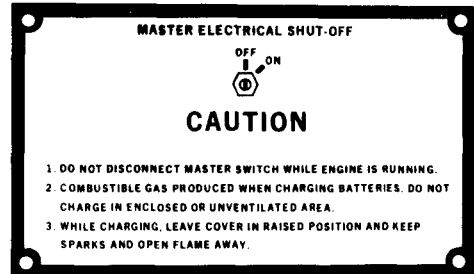
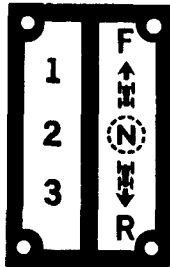

TA327947

2-22. OPERATING INSTRUCTIONS ON DECALS AND INSTRUCTION PLATES.-Continued

c. Exterior and Interior Right Side. S/N 2001 and above.

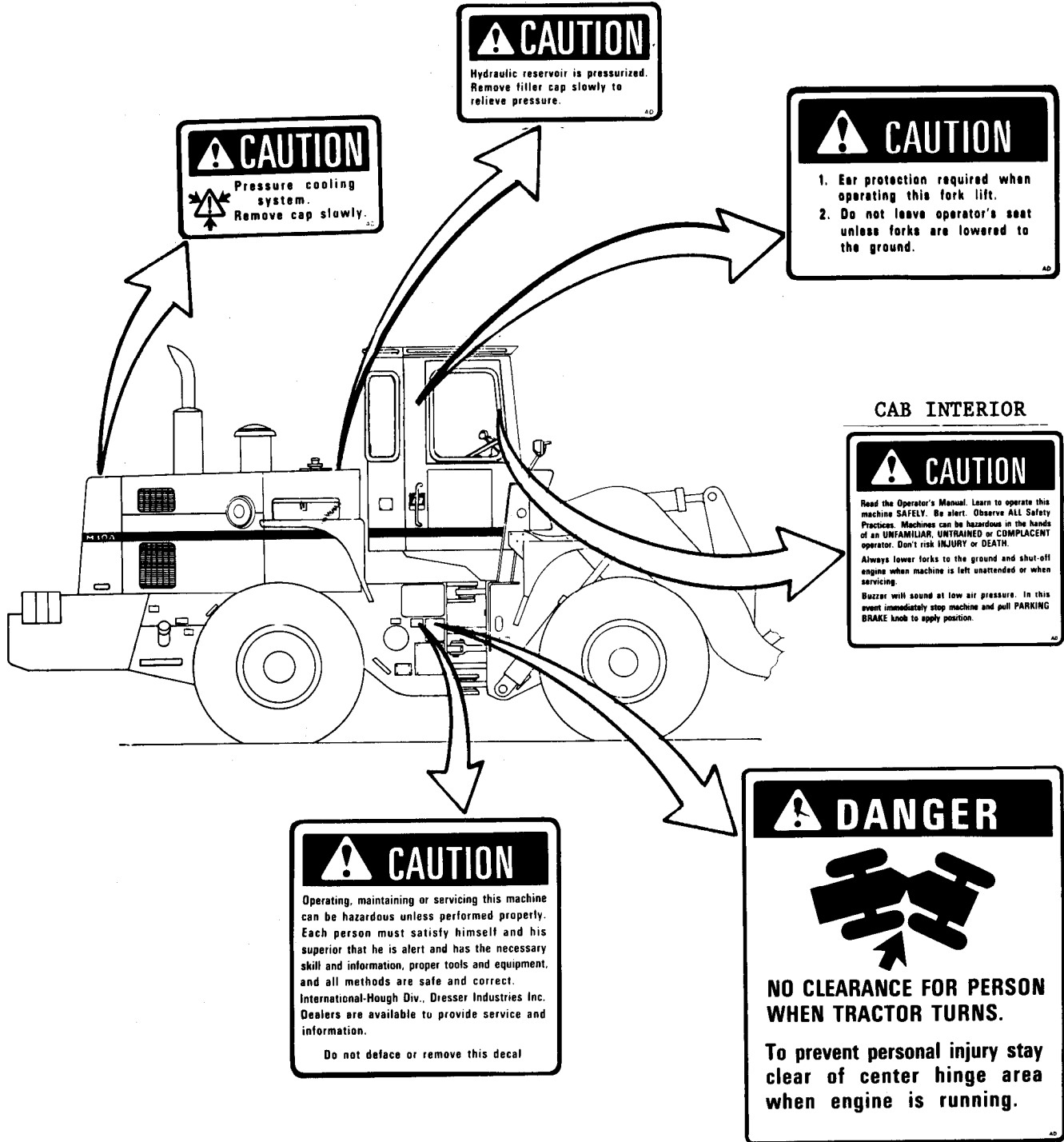

TA327979

2-22. OPERATING INSTRUCTIONS ON DECALS AND INSTRUCTION PLATES.-Continued

c. Exterior and Interior Right Side. S/N 2001 and above.

**CAB INTERIOR,
ABOVE WINDSHIELD**

CAUTION

This roll over protective structure design meets SAE performance criteria when installed in accordance with International-Hough Div., Dresser Industries Inc. mounting instructions. The protection afforded may be impaired if it has been subjected to alteration, structural damage or involved in an overturn accident. In these cases the entire structure must be replaced.

Do not deface or remove this decal

CAB INTERIOR

IMPORTANT

Fan and related components will be damaged if fan is operating or is engaged when water level is in fan sump.

ENGAGE FAN ONLY AT LOW IDLE ENGINE SPEED

RADIATOR DRAIN

IMPORTANT

TOWING INSTRUCTIONS

Driveshafts must be removed and frame locking bar must be placed in straight lock position. See operator's manual for complete instructions.

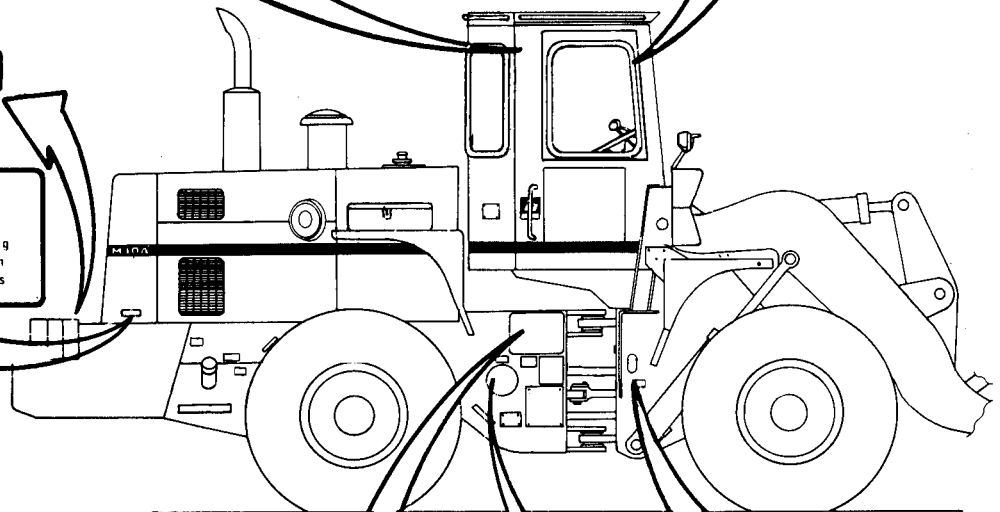

IMPORTANT

Drain moisture from reservoir daily

IMPORTANT

Check with engine at idle and transmission in neutral. Oil temperature 150° to 200°. Use 1H No.1 Engine Oil (10W).

M10A PAYLOADER				LUBRICATION CHART	
LUBRICATION INTERVAL	ITEM NO.	POINT OF LUBRICATION OR RECALL	LUBRICANT	LUBE SPEC.	REMARKS
EVERY 10 HOURS	1	COOLING SYSTEM (ENGINE & RADIATOR ABOVE 32°F BELOW 32°F)	SAE 15W/40		
	14	DIESEL ENGINE OIL (3000 TO 10000 RPM TO 100°F) (1000 TO 10000 RPM TO 100°F) (1000 TO 10000 RPM TO 100°F)	SAE 15W/40	SAE 15W/40	
	4	HYDRAULIC SYSTEM (3000 TO 10000 RPM TO 100°F) (1000 TO 10000 RPM TO 100°F)	SAE 15W/40	SAE 15W/40	
	5	TRANSMISSION (2000 TO 10000 RPM)	SAE 15W/40	SAE 15W/40	
EVERY 100 HOURS	15	FUEL SYSTEM-DIESEL (WATER SERVICE ABOVE 10°F BELOW 10°F OR FRESHWATER SERVICE)	GRADE 73-0	SAE 15W/40	
	13	REGULATED PNEUMATIC	GRADE 73-0		
	20	DRAG LINK	MULTI-PURPOSE		
	12	DRIVE SHAFT	LITHIUM BASE		
EVERY 200 HOURS	7	BATTERY	DISCHARGE		
	19	HYDRAULIC BRAKE FLUID	SAE 15W/40		
	8	TYRE CARRIER	MULTI-PURPOSE		
	11	DRIVE SHAFT	LITHIUM BASE		
EVERY 500 HOURS	10	DRIVE SHAFT	SAE 15W/40		
	18	DRIVE SHAFT	SAE 15W/40		
	16	DRIVE SHAFT	SAE 15W/40		
	17	DRIVE SHAFT	SAE 15W/40		

NOTE: LUBRICANTS REQUIRE MORE FREQUENT LUBRICATION (SEE LUBRICATION INTERVAL RANGE 10-15)

CONSULT OPERATOR'S MANUAL FOR MORE DETAILED INFORMATION.

TA3279780

2-22. OPERATING INSTRUCTIONS ON DECALS AND INSTRUCTION PLATES.-Continued

c. Exterior and Interior Right Side. S/N 2001 and above.

CAB INTERIOR

CAB INTERIOR

**READ AND UNDERSTAND
THE ENCLOSED MANUALS**

IMPORTANT

If converter temperature exceeds green zone, remove load and increase engine speed until temperature returns to green zone.

Do not operate engine above slow idle until oil pressure warning light goes off. At shut down run engine at slow idle for a minimum of three minutes.

Radiator equipped with deaeration type cooling system. After filling, run engine. When thermostats open, add more coolant until system is full.

U.S. ARMY

SER 333 602
 CONTRACT: DAAL07 81 C 6198
 ITEM NAME: COUNTERWEIGHT
 ROUGH TERRAIN FORK LIFT 10000 LB CAPACITY
 CODE:
 PART NUMBER: 1124076C1

DRESSER INDUSTRIES, INC.
 LIBERTYVILLE, ILLINOIS U.S.A.

Use No. 1 Fuel below -12°C (10°F)
 Use No. 2 Fuel above -12°C (10°F)
 See Operator's Manual.

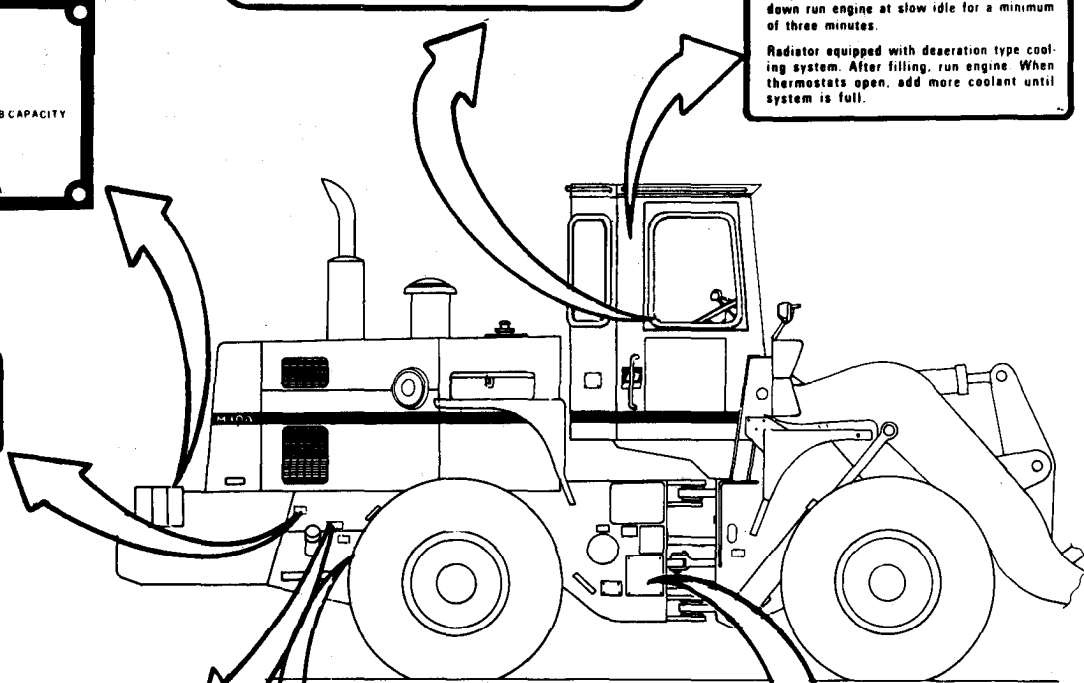

DIESEL FUEL

ENGINE OIL DRAIN

TIE DOWN DATA FOR TRUCK, LIFT, FORK, ARTICULATED FRAME
 10,000 LB CAPACITY DED 4x4

TYPICAL FREIGHT CAR TIE DOWN FOR TRUCK TRANSPORT. WHEEL BLOCKS ARE NOT REQUIRED FOR AIR TRANSPORT. ① CAB, ② COUNTERWEIGHTS, ③ MUFFLER & ④ FORKS MUST BE REMOVED. TIE DOWN CABLE TO BE 3/4 DIA IMPROVED FLOW STEEL

CAUTION
 LOCK ARTICULATION BEFORE LIFTING

TA327981

2-22. OPERATING INSTRUCTIONS ON DECALS AND INSTRUCTION PLATES.-Continued

c. Exterior and Interior Right Side. S/N 2001 and above.

U.S. ARMY
10,000 ROUGH TERRAIN FORK LIFT
MODEL M10A CONTR: DAAE07-81-C-6198
SER 333-602 CAP 10,000
SHIP WT 36,950 DATE MFD
HGT 128" W 100 5" LG: 342.5"
ENG SER CUBE 2550 FT
NSN
DRESSER INDUSTRIES, INC
LIBERTYVILLE, ILLINOIS U.S.A.

WARRANTY INFORMATION
Vehicle warranty is for 18 months or 1500 operating hours whichever occurs first.
Failed components will be repaired or replaced if attributable to defective material or workmanship.
For warranty implementation contact:
Pac Linc Group
Warranty Administration
Schiller Park, Illinois 60172
and provide: Contract no., Model no. and Serial no.

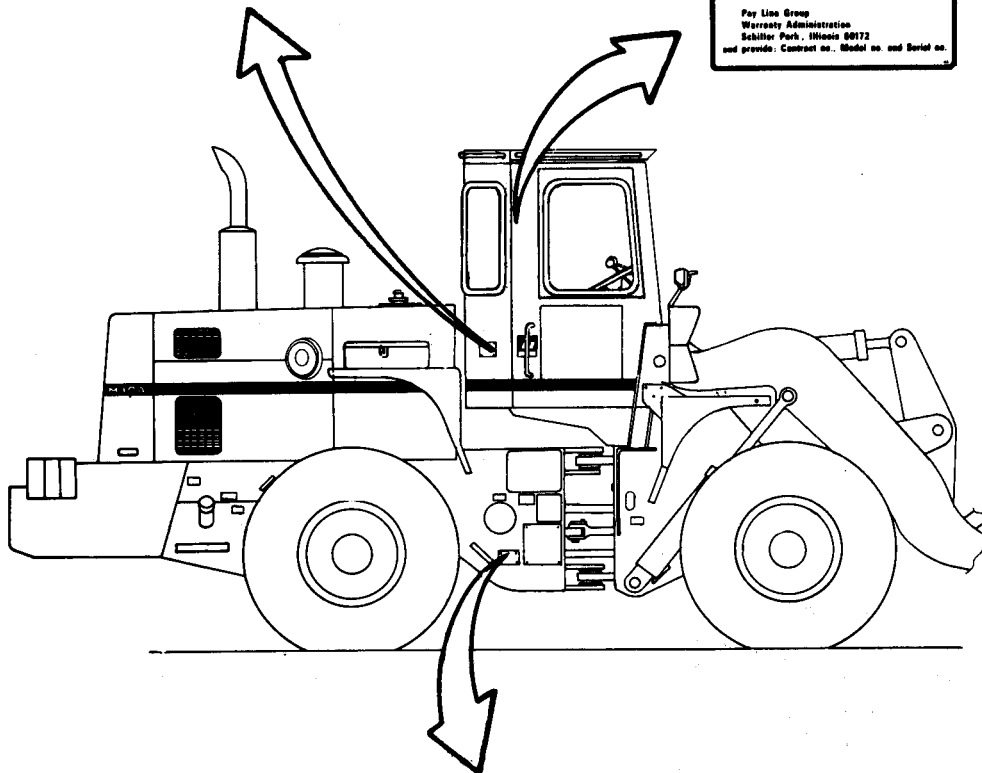

U.S. ARMY
SER 333-602
CONTRACT: DAAE07-81-C-6198
ITEM NAME: ROPS CAB
ROUGH TERRAIN FORK LIFT 10000 LB CAPACITY
CODE:
PART NUMBER: 1153685C01
DRESSER INDUSTRIES, INC
LIBERTYVILLE, ILLINOIS U.S.A.

TA327982

2-22. OPERATING INSTRUCTIONS ON DECALS AND INSTRUCTION PLATES.-Continued

d. Exterior and Interior Left Side. S/N 2001 and above.

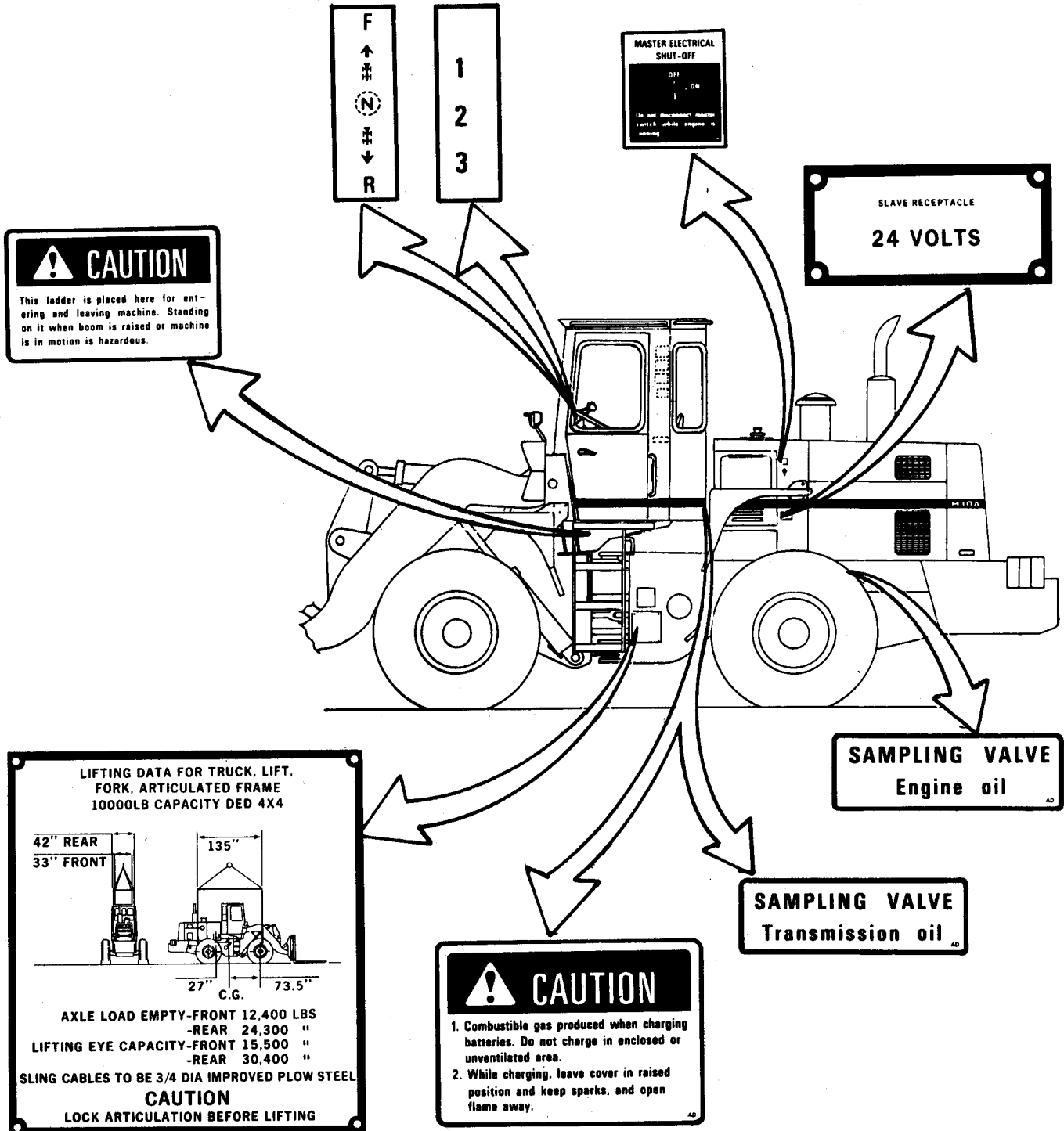

TA327983

Section IV. OPERATION UNDER UNUSUAL CONDITIONS.

2-23. OPERATION IN UNUSUAL WEATHER.

a. Extreme Cold.

(1) General. If operating an open ROPS in extreme cold, ensure that proper operator protection is worn. Extensive preparation of the forklift is required for extremely cold weather. Extreme cold causes many problems:

- Lubricants thicken or congeal.
- Batteries may freeze or lose their electrical efficiency.
- Electrical insulation may crack and cause short circuits.
- Fuel may not readily vaporize for combustion.
- Various materials will become hard, brittle, and easily damaged.

(2) Cooling system. Inspect for leaks and general condition. Make sure clamps are tight. Check fluid level in radiator. Notify organizational maintenance if system needs service.

(3) Fuel tank. Do not allow fuel tank to remain partially empty for a long period of time in extremely cold weather. Fill after each work period to help avoid water condensation in the fuel tank. Remove all ice and snow from around the fuel filler opening before refueling.

(4) Electrical system. Inspect battery cables, wiring harness, and wiring. Check for breaks or cracks caused by cold weather. Report any damage to organizational maintenance.

Save your batteries. Use lights and other electrical equipment as little as possible.

(5) Lubrication. Lubricate according to LO 10-3930-643-12. You will be provided with lubricants with a pour point below the lowest expected operating temperature.

(6) Engine operation.

(a) Before starting, make sure fuel and oil in the engine and transmission are thin enough to flow. If the oil drips from the dipstick, it is thin enough for the engine to be started.

(b) Use the ether starting aid. Refer to paragraph 2-20.

(c) Run the engine at reduced speed only long enough to circulate the oil through the engine, then increase speed and warm up the engine. Low idling speeds during extremely cold temperatures can result in incomplete combustion and the formation of heavy deposits on the valves.

2-23. OPERATION IN UNUSUAL WEATHER.-Continued

a. Extreme Cold.-Continued

(d) Observe the water temperature gage and warning light during the warm-up period to make sure that the radiator has not frozen overnight. If radiator is frozen, report to organizational maintenance.

(e) Cover radiator, if necessary, to bring engine up to operating temperature.

(7) Forklift operation.

(a) Test brakes and forklift controls carefully.

(b) Move all controls slowly to warm the hydraulic oil. Cycle each control several times. Normal warm-up period is three to ten minutes.

(c) Operate under a light load for the first five minutes of operation.

(8) At halt or parking.

(a) Park forklift in a sheltered place, if possible. Cover to protect engine, accessories, and controls from ice and snow. An open ROPS forklift must be covered.

(b) Run forklift onto planks to prevent tires from freezing to the ground. Block up forks.

(c) Be sure you clean wet snow or mud from tires and cylinders before it freezes.

(d) In extremely cold weather, notify organizational maintenance to remove the batteries and store them in a moderately warm area. Have the batteries reinstalled just before you start the engine.

b. Extreme Heat.

(1) General. Check temperature gage and light frequently for indication of overheating. Allow engine to idle slowly when it is overheated, until temperature is reduced as indicated by light going out or gage indicating normal.

(2) Cooling system.

(a) Check coolant level at frequent intervals and keep radiator cap tight. Report low coolant level to organizational maintenance.

(b) Be sure the radiator is free of bugs, dust, and other foreign matter.

(c) Check fan belt tension frequently. Report any damaged or loose belts to organizational maintenance.

(3) Lubrication. Lubricate according to LO 10-3930-643-12. You will be provided with lubricant suitable for extreme heat.

2-23. OPERATION IN UNUSUAL WEATHER.-Continued

(4) Air cleaner. Check and clean air precleaner at closer than normal intervals. Check air cleaner indicator frequently. Notify organizational maintenance if the red indicator fills the indicator viewing window.

(5) At halt or parking. Park the forklift in a shaded area, if possible.

c. Rainy or Humid Conditions.

(1) General. Protect vehicle from moisture. Keep operator's compartment as dry as possible. Do not operate an open ROPS forklift under these conditions, unless necessary.

(a) When parking an open ROPS vehicle, the operator compartment should be protected or the forklift parked under shelter.

(b) Parking on a raised or elevated area is recommended.

(2) Fuel system. Keep fuel tank full to cut down on water collecting in the fuel tank.

When adding fuel in rainy conditions, the fuel tank filler opening should be protected.

(3) Lubrication. Lubricate according to LO 10-3930-643-12.

2-24. OPERATION IN DUSTY OR SANDY AREAS.

a. General. Sand and dust are abrasive and can cause wear on many parts of the vehicle. Airborne sand and dust can clog the radiator and air cleaner.

b. Cooling System. Be sure you check the radiator frequently and keep air passages open. If coolant level is low, notify organizational maintenance.

c. Air Cleaner. Inspect and clean precleaner frequently. Check air cleaner indicator at closer than normal intervals. Notify organizational maintenance if red indicator fills the indicator viewing window.

d. Lubrication. Lubricate according to LO 10-3930-643-12. Lubricate at more frequent intervals. Take special care cleaning fittings and lubrication openings. Keep dust and dirt out of lubricants.

e. Tire Pressure. When operating the forklift on soft sand at slow speeds, the tire inflation pressure may be decreased to 40 psi in the front tires and 25 psi in the rear tires. Refer to organizational maintenance.

CAUTION

After completing operation in sandy terrain the tire air pressure must be returned to normal (50 psi) before resuming work on average or hard surface. Refer to organizational maintenance.

2-24. OPERATION IN DUSTY OR SANDY AREAS.-Continued

f. At Halt. When the forklift is not in use, cover the open ROPS operator's compartment, and utilize whatever means are available to protect the engine compartment from the entry of windblown dust or sand.

2-25. OPERATION IN SALTWATER AREAS. Keep forklift as clean as possible. After use, wash with fresh water. Keep all lubrication points clean. Refer to organizational maintenance. Keep all wiring and connections clean and free from corrosion.

2-26. OPERATION AT HIGH ALTITUDES. Keep a constant watch on coolant level. If coolant is needed notify organizational maintenance. Keep close watch on engine instruments during operation. NOTE: Engine will operate at less than peak performance at high altitudes.

2-27. OPERATION IN SNOW. Keep fuel tank full, and keep snow and ice away from fuel filler when servicing the forklift. When parking an open ROPS forklift the operator's compartment should be protected or the forklift parked under shelter.

2-28. FORDING. This forklift may be safely subjected to depths of 60 inches of water including wave action. Do not exceed this depth.

a. Before Fording.

(1) Check the depth of the water allowing for the consistency of the bottom.

(2) Raise forks above water level.

CAUTION

Engage or disengage the fan only when the engine is operating at low idle.

b. Entering Water.

(1) Turn the fan switch to OFF if chance of water level entering the fan sweep.

(2) Increase engine speed to reduce danger of stalling.

NOTE

Leave transmission selector in range 1.

(3) Enter the water slowly to minimize surges of backwash into the engine compartment. Speed must not exceed three to four mph. If stalling occurs, notify organizational maintenance.

(4) When operating with the fan off, watch the water temperature gage closely. If overheating is indicated, immediately move to more shallow water and turn the fan on.

2-31. FORDING.-Continued

c. After Fording.

- (1) Turn the fan switch to ON when the fan sweep clears the water level.
- (2) Lubricate the forklift completely as soon as possible after fording.
Refer to organizational maintenance.

CHAPTER 3

MAINTENANCE INSTRUCTIONS

CHAPTER OVERVIEW

The purpose of this chapter is to provide you with lubrication instructions, troubleshooting and maintenance procedures to help you keep your vehicle in good running order.

INDEX

<u>Section</u>	<u>Title</u>	<u>Paragraph</u>	<u>Page</u>
I	LUBRICATION		
	Lubrication Instructions	3-1	3-1
	Lubrication Information	3-2	3-2
II	OPERATOR/CREW TROUBLESHOOTING PROCEDURES		
	Troubleshooting Information	3-3	3-2
	Troubleshooting Symptom Index	3-4	3-3
	Troubleshooting Procedures	3-5	3-4
III	MAINTENANCE PROCEDURES		
	Operator Maintenance	3-6	3-12

Section I. LUBRICATION

3-1. LUBRICATION INSTRUCTIONS.

- a. For lubrication under normal conditions, refer to LO 10-3930-643-12.
- b. For instruction on lubrication in weather below 0 degrees F (-18 degrees C), refer to FM 9-207. See Appendix A.
- c. For lubrication before and after fording, refer to TM 9-238. See Appendix A.
- d. After operating in dusty or sandy conditions, clean and inspect all lubrication points. Lubricate vehicle in accordance with LO 10-3930-643-12.

3-2. LUBRICATION INFORMATION.

a. Care of Lubricants. Keep all lubricants in clean, closed containers and store in a dry area away from external heat. Don't allow dust, dirt, or other foreign matter to mix with lubricants during storage or use. Keep all lubrication clean and ready for use.

b. Cleaning. Keep all external parts that do not require lubrication free of lubricants. Use a clean cloth to wipe all dirt and other foreign matter from lubrication points. Clean caps, covers, plug and surrounding area before removing them from the vehicle. Clean lubrication points after lubrication to prevent accumulation of foreign matter.

c. Points of Lubrication. Refer to LO 10-3930-643-12 for lubrication points and intervals of lubrication.

Section 11. OPERATOR/CREW TROUBLESHOOTING PROCEDURES

3-3. TROUBLESHOOTING INFORMATION. Paragraph 3-4 lists the common malfunctions which you may find during the operation or maintenance of the vehicle. You should perform the tests/inspections and corrective actions in the order listed.

This manual cannot list all malfunctions that may occur, nor all tests, inspections, or corrective actions. If a malfunction is not listed, or is not corrected by listed corrective actions, notify your supervisor.

3-4. TROUBLESHOOTING SYMPTOM INDEX.

Troubleshooting
Procedure Page

ENGINE

Engine fails to crank, or cranks slowly when starter switch is activated	3-4
Engine cranks but fails to start	3-5
Engine starts but will not continue to run or shows loss of power	3-6
Excessive oil consumption	3-7
Engine overheats (coolant temperature gage is not in normal operating range)	3-7
Low or no oil pressure	3-8
Excessive engine exhaust smoke	3-8

TRANSMISSION

Transmission does not drive in any range	3-8
Transmission overheating	3-9

STEERING

Forklift difficult to steer	3-9
-----------------------------	-----

VOLTMETER

Voltmeter indicates battery condition (partially charged) (gage needle below low green area)	3-10
Voltmeter indicates alternator circuit undercharging (gage needle below high green area)	3-11

HYDRAULIC EQUIPMENT

Hydraulic equipment does not operate properly	3-11
---	------

MALFUNCTION

TEST OR INSPECTION

CORRECTIVE ACTION

1. ENGINE FAILS TO CRANK, OR CRANKS SLOWLY WHEN STARTER SWITCH IS ACTIVATED.

CAUTION

After every 30 seconds of cranking, allow two minutes for the starter motor to cool.

Step 1. Check to see if master disconnect switch is on.

S/N 2000 and below - If off, insert key, and turn switch to right.

S/N 2001 and above - If off, turn switch to right.

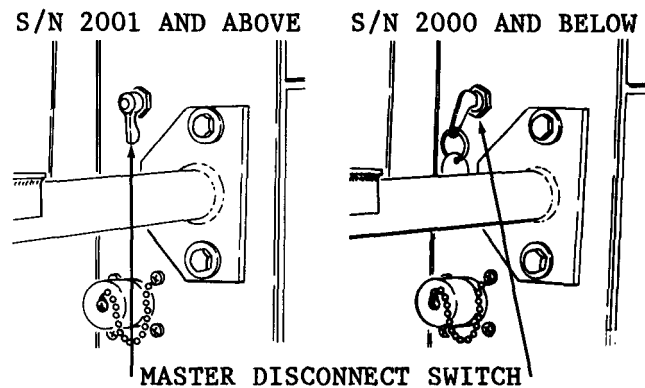

WARNING

CHEMICAL BURN HAZARD

Sulfuric acid contained in batteries can cause severe chemical burns if not handled properly.

WARNING

FLAMMABLE

Battery gases are flammable and can explode if not handled properly.

Step 2. Check battery electrolyte level. Refer to paragraph 3-6.

If low, refer to organizational maintenance.

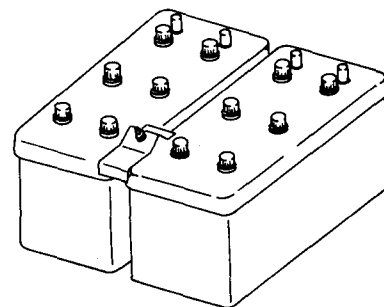

TA327984

3-5. TROUBLESHOOTING PROCEDURES.-Continued

MALFUNCTION

TEST OR INSPECTION

CORRECTIVE ACTION

1. ENGINE FAILS TO CRANK, OR CRANKS SLOWLY WHEN STARTER SWITCH IS ACTIVATED.-
Continued

Step 3. Check to see if battery cables are loose, broken, or corroded.

If loose, corroded or broken, notify organizational maintenance.

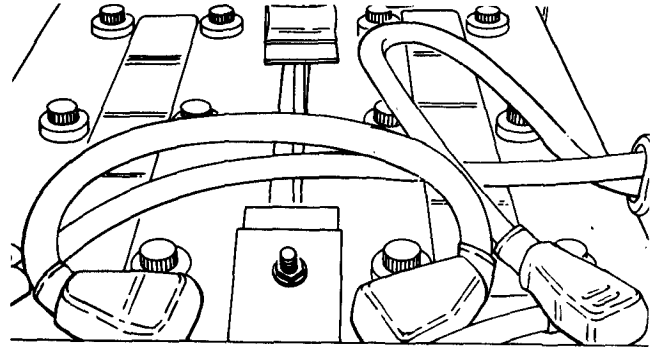

2. ENGINE CRANKS BUT FAILS TO START.

Step 1. Check fuel level.

If no fuel, refill.

Step 2. Check for broken, leaking, or kinked fuel lines and hoses.

If fuel lines and hoses are broken, leaking, or kinked, notify organizational maintenance.

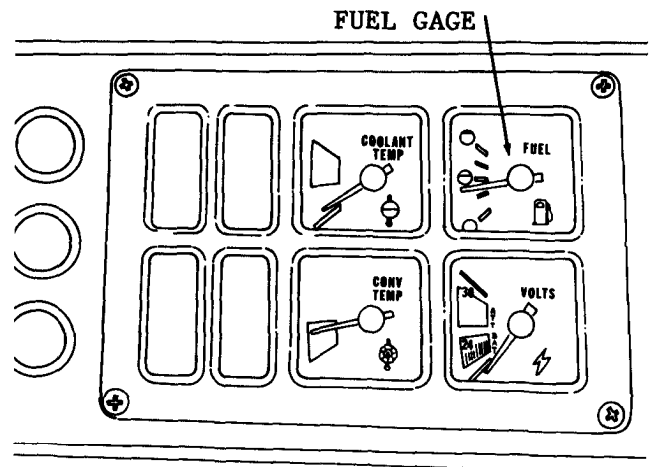

TA327985

3-5. TROUBLESHOOTING PROCEDURES.-Continued

MALFUNCTION

TEST OR INSPECTION

CORRECTIVE ACTION

2. ENGINE CRANKS BUT FAILS TO START.-Continued

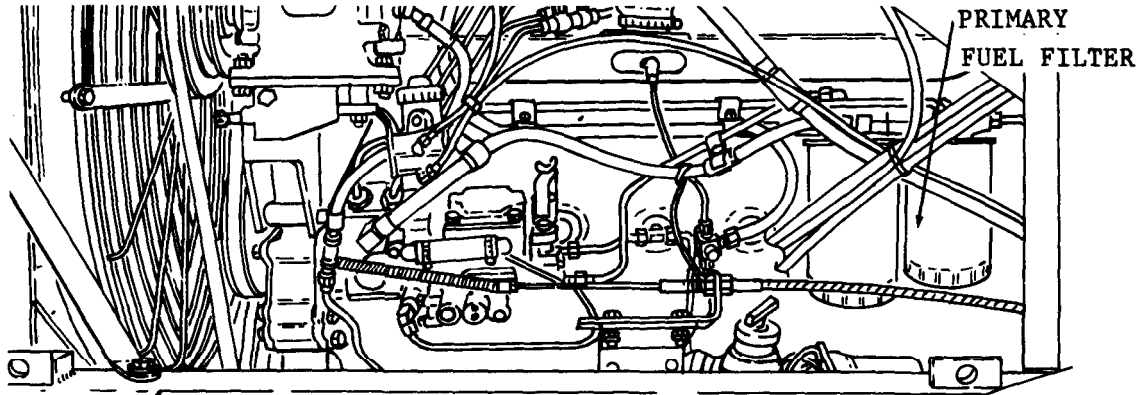

TA327986

Step 3. Drain primary fuel filter till clear fuel flows (S/N 2001 and above only). If procedure fails to correct malfunction, refer to organizational maintenance.

3. ENGINE STARTS BUT WILL NOT CONTINUE TO RUN OR SHOWS LOSS OF POWER.

Step 1. Check to see if accelerator pedal is bent or binding.

If bent or binding, notify organizational maintenance.

Step 2. Check for broken, leaking, or kinked fuel lines and hoses.

If fuel lines and hoses are broken, leaking, or kinked, notify organizational maintenance.

Step 3. Drain primary fuel filter until clear fuel flows (S/N 2001 and above). If procedure fails to correct malfunction, refer to organizational maintenance.

3-5. TROUBLESHOOTING PROCEDURES.-Continued

MALFUNCTION

TEST OR INSPECTION

CORRECTIVE ACTION

4. EXCESSIVE OIL CONSUMPTION.

CAUTION

Check for oil leaks at oil filter and oil pan drain plug.

If leaking, notify organizational maintenance.

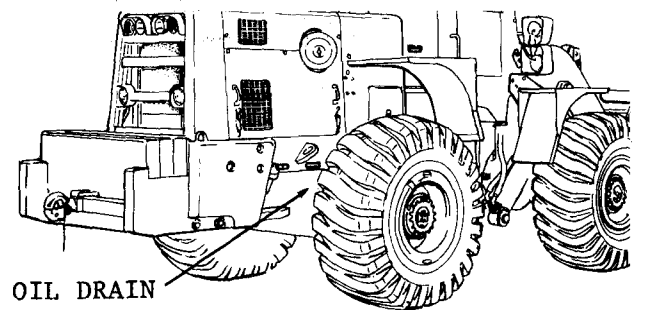
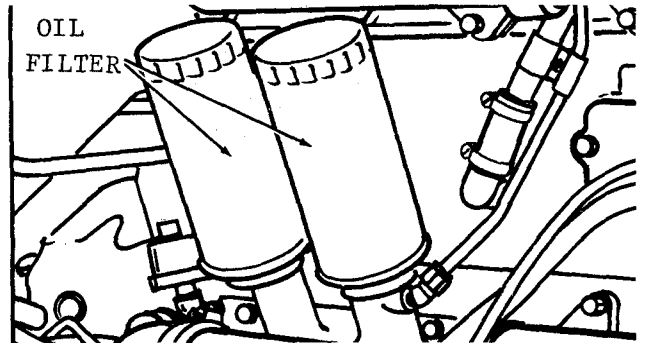

5. ENGINE OVERHEATS (COOLANT TEMPERATURE GAGE IS NOT IN NORMAL OPERATING RANGE).

If engine is not running, start engine immediately.

Step 1. Check to see if fan switch is on.

WARNING

STEAM HAZARD

When engine is hot, remove radiator cap slowly to relieve pressure. Use gloves and protective clothing. Failure to follow these instructions could result in SEVERE INJURY.

Step 2. Check to see if engine coolant is low and if any leaks are visible.

If low or if leak is found, notify organizational maintenance.

Step 3. Check cooling fan for damage.

Report any damage to organizational maintenance.

TA327987

3-5. TROUBLESHOOTING PROCEDURES.-Continued

MALFUNCTION

TEST OR INSPECTION

CORRECTIVE ACTION

5. ENGINE OVERHEATS (COOLANT TEMPERATURE GAGE IS NOT IN NORMAL OPERATING RANGE).-Continued

Step 4. Check to see if radiator grille is obstructed or damaged.

If obstructed, clean. Report any damage to organizational maintenance.

6. LOW OR NO OIL PRESSURE.

Check to see if engine oil is low, and if any leaks are visible. Report low engine oil or leaks to organizational maintenance.

If low, fill with approved engine oil. Refer to LO 10-3930-643-12. Notify organizational maintenance.

7. EXCESSIVE ENGINE EXHAUST SMOKE.

Notify organizational maintenance if there is excessive engine exhaust smoke.

8. TRANSMISSION DOES NOT DRIVE IN ANY RANGE.

Check transmission fluid level.

If low, refill. Refer to LO 10-3930-643-12. Notify organizational maintenance.

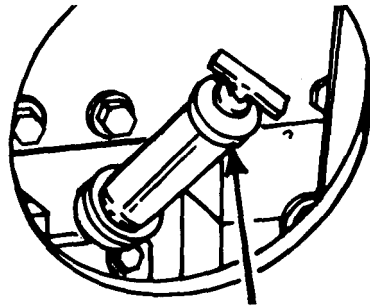

TA327988

TRANSMISSION
DIPSTICK

3-5. TROUBLESHOOTING PROCEDURES.-Continued

MALFUNCTION

TEST OR INSPECTION
CORRECTIVE ACTION

9. TRANSMISSION OVERHEATING.

Check transmission dipstick for excessively high level.

If high, notify organizational maintenance.

10. FORKLIFT DIFFICULT TO STEER.

Step 1. Visually check tires for proper inflation. Check rims for damage. If tires are low or rims are damaged, notify organizational maintenance.

Step 2. Check hydraulic reservoir fluid level in the sight gage.

If low, refill. Refer to
LO 10-3930-643-12.

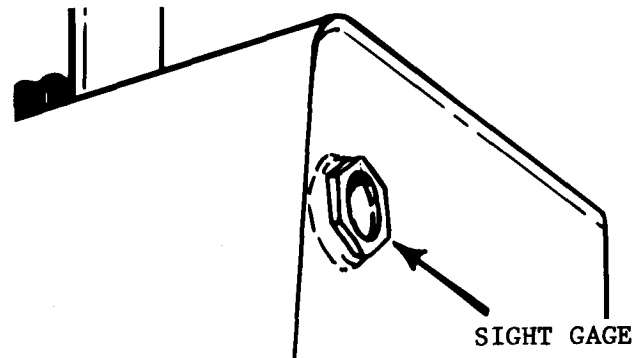

TA327989

3-5. TROUBLESHOOTING PROCEDURES.-Continued

MALFUNCTION

TEST OR INSPECTION

CORRECTIVE ACTION

10. FORKLIFT DIFFICULT TO STEER,-Continued

Step 3. Check for damaged or leaking cylinders, or damaged lines or fittings.

If leaking or damaged, notify organizational maintenance.

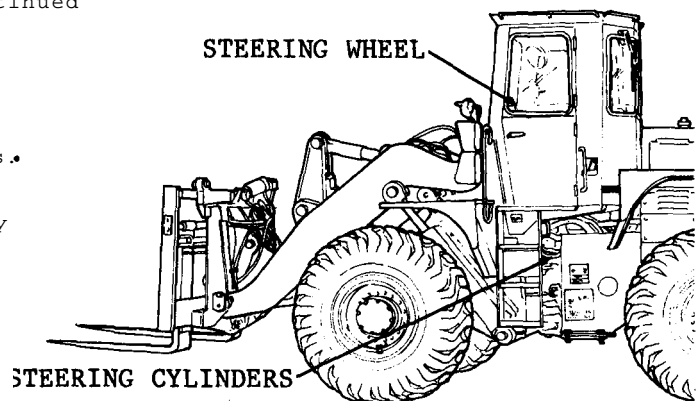

11. VOLTMETER INDICATES BATTERY CONDITION (PARTIALLY CHARGED) (GAGE NEEDLE BELOW LOW GREEN AREA).

WARNING

- Sulfuric acid contained in batteries can cause severe chemical burns if not handled properly.
- Battery gases are flammable and can explode if not handled properly.

Step 1. Check battery electrolyte level. If low, notify organizational maintenance.

Step 2. Check to see if battery cables are loose, broken, or corroded. If SO, notify organizational maintenance.

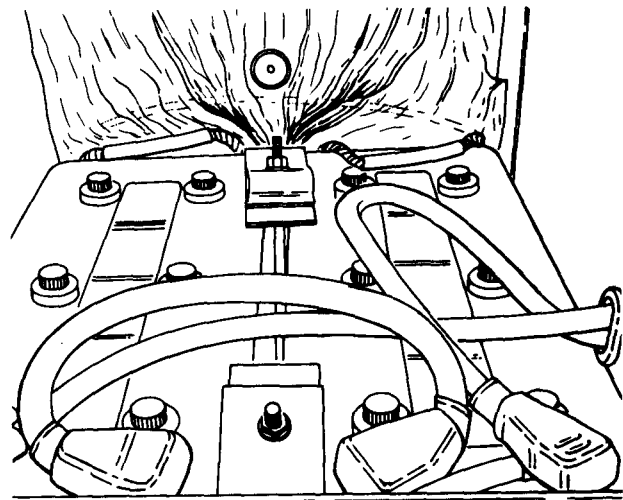

TA327990

3-5. TROUBLESHOOTING PROCEDURES.-Continued

MALFUNCTION

TEST OR INSPECTION
CORRECTIVE ACTION

12. VOLTMETER INDICATES ALTERNATOR CIRCUIT UNDERCHARGING (GAGE NEEDLE BELOW HIGH GREEN AREA).

Step 1. Check alternator drive belt for frayed or damaged condition.

Report frayed or damaged condition to organizational maintenance.

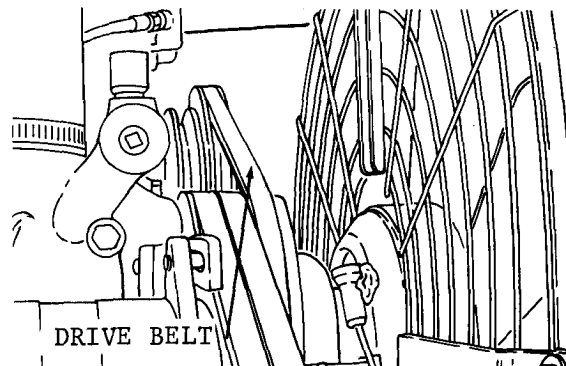

Step 2. Check to see if alternator cables are loose, broken, or corroded.

Report loose, broken, or corroded cables to organizational maintenance.

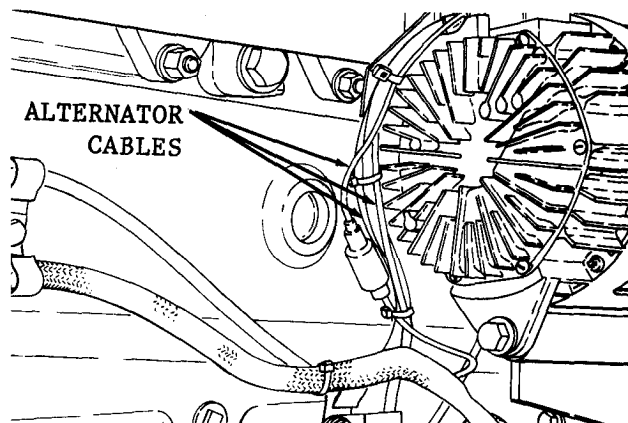

NOTE

If voltmeter indicates overcharge (gage needle above green area), notify organizational maintenance.

13. HYDRAULIC EQUIPMENT DOES NOT OPERATE PROPERLY.

Step 1. Check hydraulic fluid level in the sight gage.

If low, fill to proper level. Refer to LO 10-3930-643-12. Notify organizational maintenance.

Step 2. Check for leaks in hydraulic lines, fittings and at cylinders.

Report leaks to organizational maintenance.

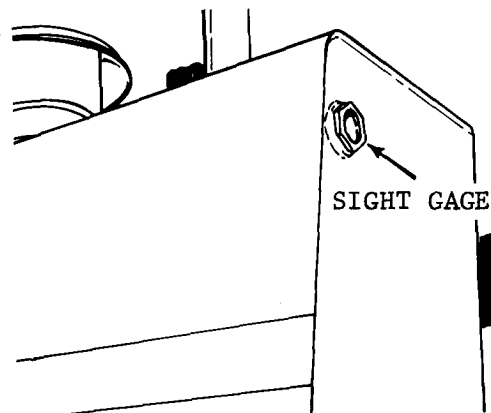

TA327991

3-6. OPERATOR MAINTENANCE.

a. Battery Servicing. This task covers cleaning battery terminals and checking battery fluid level.

INITIAL SETUP

Materials/Parts

Clean cloths

Item 1, Appendix D

EQUIPMENT CONDITION

Condition Description

Forklift parked on level ground.

Forks lowered.

Engine off.

Parking/emergency brake applied.

Master disconnect switch to ON.

3-6. OPERATOR MAINTENANCE.-Continued

STEP	LOCATION	ITEM	ACTION	REMARKS
------	----------	------	--------	---------

SERVICING

WARNING

- Sulfuric acid contained in batteries can cause severe chemical burns if not handled properly.
- Battery gases are flammable and can explode if not handled properly.

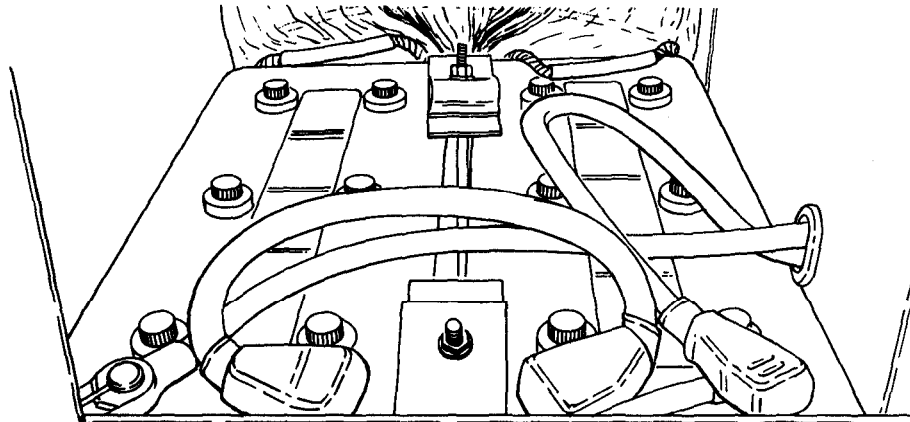

TA327992

1	Forklift, left side	a. Battery compartment door	Open	
		b. Batteries	a. Clean tops and terminals	Use clean cloths
			b. Check level	
		c. Battery compartment door	Close and latch securely	

3-6. OPERATOR MAINTENANCE.-Continued

b. Air System Venting (draining). This task covers venting (draining) the air system.

INITIAL SETUP

Materials/Parts

None

EQUIPMENT CONDITION

Condition Description

Forklift parked on level ground.
 Forks lowered.
 Engine off.
 Parking/emergency brake applied.

STEP	LOCATION	ITEM	ACTION	REMARKS
------	----------	------	--------	---------

SERVICING - Continued

WARNING

Do not stand in direct line with or look at vented air stream.
 Failure to observe the above could result in foreign debris being blown into the eyes.

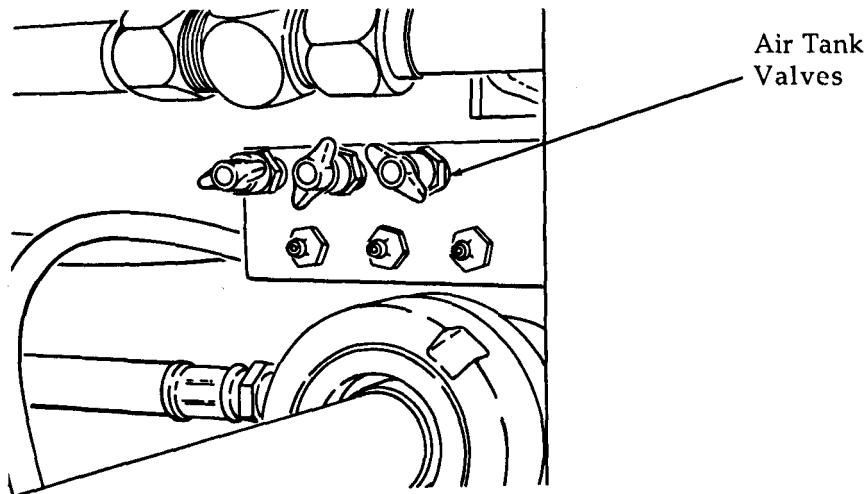

2	Forklift, left side	Air Tank Valves (3 each)	Open	Allow system to drain completely.
---	------------------------	-----------------------------	------	-----------------------------------

APPENDIX A

REFERENCES

A-1 . PUBLICATION INDEXES AND GENERAL REFERENCES.

Indexes should be consulted frequently for latest changes or revisions of references given in this appendix and for new publications relating to material covered in this publication.

a. MILITARY PUBLICATION INDEXES.

Consolidated Index of Publications and Blank FormsDA PAM 310-1

b. GENERAL REFERENCES.

Dictionary of United States Army TermsAR 310-25
 Authorized Abbreviations and Brevity CodesAR 310-50
 Military Training Management.TC 21-5-7
 Military SymbolsFM 21-30

A-2. OTHER PUBLICATIONS.

The following publications contain information pertinent to the major item materiel and associated equipment.

a. VEHICLE.

Truck, Forklift, DED Pneumatic Tire, 10,000 LB.
 Capacity Rough Terrain, Articulated Frame Steer
 (Dresser Industries Model M10A, MHE 236L0 10-3930-643-12

b. CAMOUFLAGE.

CamouflageFM 5-20

c. DECONTAMINATION.

Chemical, Biological, and Radiological
 Decontamination.TM 3-220
 Chemical, Biological, Radiological, and Nuclear DefenseTM 21-40

d. GENERAL.

Accident Reporting and RecordsAR 385-40
 Basic Cold WeatherFM 31-70
 Cooling Systems: Tactical VehiclesTM 750-254
 Manual for Wheeled Vehicle DriverFM 21-305
 Driver Selection and Training (Wheeled Vehicles)FM 55-30
 Mountain OperationsFM 90-6
 Northern OperationsFM 31-71
 Operation and Maintenance of Ordnance Materiel in
 Cold Weather (0°F. to -65°F.)FM 9-207
 Principles of Automotive VehiclesTM 9-8000
 Prevention of Motor Vehicle AccidentsAR 385-55
 Procedures for Destruction of Tank Automotive Equipment
 to Prevent Enemy UseTM 750-244-6

REFERENCES (cont)

A-2 . OTHER PUBLICATIONS. (cont)

e. FIRST AID.

First Aid for SoldiersFM 21-11

f. MAINTENANCE AND REPAIR.

Organizational, Direct Support and General Support Care,
Maintenance and Repair:

Pneumatic Tires and Inner TubesTM 9-2610-200-24

Description, Use, Bonding Techniques and
Properties of AdhesivesTB ORD 1032

Inspection, Care, and Maintenance of Antifriction
BearingsTM 9-214

Materials Used for Cleaning, Preserving, Abrading,
and Cementing Ordnance Materiel and Related

Materiels Including ChemicalsTM 9-247

Metal Body Repair and Related OperationsFM 43-2

Operation and Organizational Maintenance Manual for
Lead-Acid Storage BatteriesTM 9-6140-200-14

Organizational, Policies, and Responsibilities for
Army Materiel Maintenance Concepts and PoliciesAR 750-1

Use of Antifreeze Solutions and Cleaning Compounds
in Engine Cooling SystemTB 750-651

Welding Theory and ApplicationTM 9-237

Color, Marking, and Camouflage Painting of Military
Vehicles Construction Equipment, and Materials

Handling Equipment,,TB 43-0209

g. SHIPMENT AND LIMITED STORAGE.

Color Marking, and Preparation of Equipment for

Shipment of Army MaterielAR 746-1

Preservation and Packing of Military
Supplies and EquipmentTM 38-230-1 & 2

Preservation of USAMECOM Mechanical Equipment
for Shipment and StorageTB 740-97-2

Preservation, Packaging, Packing and Marking
Materials, Supplies, and Equipment Used by

the ArmySB 38-100

Shipment and Limited StorageMIL-V-62038

Storage and Serviceability Standard: Tracked
Vehicles, Wheeled Vehicles and Component PartsSB 40-98-1

Storage and Supply Activities: Covered and Open
StorageSB 740-1

The Army Maintenance Management Systems (TAMMS)DA PAM 738-750

APPENDIX B

COMPONENTS OF END ITEM AND BASIC ISSUE ITEMS LISTS

NOT APPLICABLE

APPENDIX C

ADDITIONAL AUTHORIZATION LIST

Section I. INTRODUCTION

C-1. SCOPE. This appendix lists additional items you are authorized for support of the MHE236 Forklift.

C-2. GENERAL. This list identifies items that do not have to accompany the MHE236 Forklift and that do not have to be turned in with it. These items are all authorized to you by CTA, MTOE, TDA or JTA.

C-3. EXPLANATION OF LISTING. National stock numbers, descriptions, and quantities are provided to help you identify and request the additional items you required to support this equipment.

Section II. ADDITIONAL AUTHORIZATION LIST

(1)		(2)		(3)	(4)
National		Description		U/M	Qty.
Stock					Auth.
Number	Part Number and FSCM			Usable on Code	
4210-00-889-2221	CS4210-0009CEF (16236)	Fire Extinguisher, Dry Chemical		EA	1
7520-00-559-9618	MIL-C-11743 (81349)	Case, Maintenance		EA	1

APPENDIX D

EXPENDABLE/DURABLE SUPPLIES AND MATERIALS LIST

Section I. INTRODUCTION

D-1. SCOPE . This appendix lists expendable consumable maintenance supplies you will need to operate and maintain the MHE236 Forklift. This listing is for informational purposes only and is not authority to requisition the listed items. These items are authorized to you by CTA 50-970, Expendable/Durable Items (Except Medical, Class V, Repair Parts, and Heraldic Items), or CTA 8-100, Army-Medical Department Expendable/Durable Items.

D-2. EXPLANATION OF COLUMNS.

a. Item Number (Column (1)). This number is assigned to the entry in the listing and is referenced in the narrative instructions to identify the material (e.g., "Use cleaning compound, item 11, App. F").

b. Level (Column (2)). This column identifies the lowest level of maintenance that requires the listed item.

C - Operator/Crew
 O - organizational Maintenance
 F - Direct Support Maintenance
 H - General Support Maintenance

c. National Stock Number (Column (3)). This is the national stock number assigned to the item; use it to request or requisition the item.

d. Description (Column (4)). Indicates the federal item name, and if required, a description to identify the item. The last line for each item indicates the part number followed by the Federal Supply Code for Manufacturer (FSCM) in parenthesis, if applicable.

e. Unit of Measure (U/M) (Column (5)). Indicates the measure used in performing the actual maintenance function. This measure is expressed by a two-character alphabetical abbreviation (e.g., ea, in, pr). If the unit of measure differs from the unit of issue, requisition the lowest unit of issue that will satisfy your requirements.

Section II. EXPENDABLE SUPPLIES AND MATERIALS LIST

(1) Item Number	(2) Level	(3) National Stock Number	(4) Description	(5) U/M
1	C	7920-00-205-3570	RAG, WIPING: DD-R-30, A-A-531 (58536) (81348)	BE
2	C	9150-01-178-4726	LUBRICATING OIL ENG: 1 QT. BOTTLE, OE/HDO/30 (81349)	QT
3	C	9150-01-177-3988	HYDRAULIC FLUID: MIL-L-2104, 1 QT. BOTTLE, OE/HDO/10	QT
4	C	6850-00-281-3061	DRY CLEANING SOLVENT: 4 OZ. CAN, P-D-680 (81348)	CN

INDEX

SUBJECT	PAGE	SUBJECT	PAGE
A		C-Continued	
Abbreviations, list of	1-5		
Accelerator	2-9	Transmission shift control lever	2-10
Additional Authorization List	C-2	Windshield wiper	2-12
After fording	2-57	Controls	
"After" operator/crew PMCS table	2-28	Foot	2-3
Air cleaner indicator	2-13	Heater	2-12
Air system	1-20	Rear window wiper	2-12
Air tanks, servicing	2-28	Transmission	1-19
Appendix A (references)	A-1	Window	2-11
Appendix B (COEL and BII lists)	B-1	Coolant level sight gage	2-13
Appendix C (AA list)	C-1	Cooling system	1-15
Appendix D (expendable)	D-1		
B		D	
Backup alarm S/N 2001 and above	1-19	Decals and instruction plates	2-44
Battery, servicing	3-12	Defroster fan speed switch	2-12
Before fording	2-56	Description and use of operators controls and indicators	2-3
"Before" operator/crew PMCS table	2-17	Differences between models	1-8
Boom prop	1-10	Dimensions	1-13
Brake and transmission disconnect pedal	2-9	Dipstick, engine oil	2-13
Brake, pedal	2-9		
Brakes, emergency/parking	1-21		
Brakes, service	1-21		
c		E	
Capabilities and features	1-6	Electrical system	1-16
Capacities	1-13	Engine	1-14
Characteristics	1-6	Engine oil dipstick	2-13
Charging circuit	1-17	Engine oil sample valve	1-9
Components of Basic Issue List	B-1	Engine, servicing	2-12
Components of End Item List	B-1	Equipment characteristics, capabilities and features	1-6
Console, instrument	2-4	Equipment data	1-13
Control		Equipment description and data	1-6
Accelerator	2-9	Ether starting aid	2-34
Brake pedal	2-9	Exhaust system	1-15
Parking brake	2-6	Expendable Supplies and Materials List	D-2
Rear window wiper	2-12		
Transmission disconnect pedal	2-9		
Transmission safety lock	2-9		

INDEX

SUBJECT	PAGE	SUBJECT	PAGE
E-Continued		H	
Extreme cold (operation in)		Hand receipt information	1-3
At halt or parking	2-54	Hand throttle control	2-8
Cooling system	2-53	Heater controls	2-12
Electrical system	2-53	Horn	1-18
Engine operation	2-53	Hourmeter	1-18
Fuel tank	2-53	Hydraulic reservoir	
General	2-53	sight gage	3-11
Lubrication	2-53	Hydraulic system and	
Forklift operation	2-54	implements	1-22
Extreme heat (operation in)			
Air cleaner	2-55		
At halt or parking	2-55		
Cooling system	2-54		
General	2-54		
Lubrication	2-54		
			I
		Indicators	
		Air cleaner	2-13
		Engine coolant	
		temperature	2-4
		Engine fan "OFF"	2-4
		Engine oil pressure	2-4
		Ground driven	
		steering	2-4
		Hydraulic filter	2-4
		Low air pressure	2-4
		Parking brake	2-4
		Service brake	2-4
		Torque converter	
		temperature	2-4
		Initial adjustments,	
		daily checks and	
		self tests	2-31
		Instrument console	2-4
		Introductory material,	
		PMCS	2-14
			L
		Leakage definitions	2-16
		Lift control lever	2-10
		List of abbreviations	1-5
		Location and description	
		of major components	1-7
		Locks, window	2-11
		Low air warning signal	1-20
		Lubrication	
		Information	3-2
		Instructions	3-1
	F		
Fording	2-56		
Fork carriage operation	2-39		
Fork control lock	2-10		
Fork positioner	2-10		
Forklift operation	2-31		
Forward and backward			
seat adjustment	2-31		
Fuel system	1-14		
			G
Gages			
Air system pressure	2-5		
Coolant level sight gage	2-13		
Engine coolant			
temperature	2-5		
Engine oil pressure	2-5		
Fuel level	2-5		
Hourmeter	2-5		
Hydraulic reservoir			
s i g h t	3-11		
Torque converter			
temperature	2-5		
Voltmeter	2-5		
General information	1-3		

INDEX

SUBJECT	PAGE	SUBJECT	PAGE
M			
Maintenance forms and records	1-3	Parking and emergency brake controls	1-21
Maintenance instructions	3-1	Parking the forklift	2-43
Maintenance procedures	3-12	PMCS introductory material	2-14
Master disconnect switch	2-13	Preparation for movement	2-44
MHE 236 Fork Truck (illustration)	1-0	Pressure air, vented	
Mode selector switch	2-11	Pressure hydraulic, vented	
Moving the forklift	2-35	Preventive maintenance checks and services	2-14
		Principles of operation	1-14
O			
Operating instructions	2-31	Radiator, servicing	2-18
Operating instructions on decals and instruction plates	2-45	Raincap S/N 2000 and below	1-15
Operating procedures	2-31	Rainy or humid conditions (operation in)	
Operation at high altitudes	2-56	General	2-55
Operation in dusty or sandy areas		Fuel system	2-55
Air cleaner	2-55	Lubrication	2-55
At halt or parking	2-56	Rear window wiper control	2-12
Cooling system	2-55	Reference material	
General	2-55	Reporting equipment improvement recommendations (EIR)	i
Lubrication	2-55		s
Tire pressure	2-55	Scope	1-3
Operation in saltwater areas	2-56	Service brake pressure converter warning signal	1-11
Operation in snow	2-56	Service brakes	2-9
Operation in unusual weather	2-53	Servicing	
Operation under unusual conditions	2-53	Air tanks	2-28
Operation under usual conditions	2-31	Battery	3-12
Operator crew troubleshooting procedures	3-4	Engine	3-5
Operator maintenance	3-12	Fuel tank	2-29
Operator's compartment	2-3	Radiator	2-18
Operator's PMCS table	2-17	Shifting transmission gears	2-37
Oscillate lever	2-10	Sideshift lever	2-10
		Slave starting engine	2-34
		Starting aids	2-34
		Batteries	3-12
		Ether starting	2-33

INDEX

SUBJECT	PAGE	SUBJECT	PAGE
S-Continued		T-Continued	
Slave starting the engine	2-34	Torque converter temperature gage	2-5
Winter oils	2-34	Transmission	
Starting circuit	1-16	Direction lever	2-9
Starting motor	1-16	Gear range lever	2-9
Starting the engine	2-32	Safety lock	2-9
Steering	2-40	Transmission controls	1-17
Steering wheel	2-8	Transmission disconnect pedal	1-17
Stopping the engine	2-40	Troubleshooting	
Stopping the forklift	2-38	Information	3-2
Switches		Procedures	3-4
Backup alarm	1-19	Symptom Index	3-3
Defroster fan	2-12		
Ether starting switch	2-8		
Fan	2-12		
Front service light	1-17	V	
Horn button	1-18		
Main (light)	2-9	Voltmeter	
Parking/emergency brake control	1-21		
Rear service light	1-17	W	
Start	2-32		
Temperature (heater)	2-12	Warnings	a
Vehicle light	1-17	Warranty information	1-4
Windshield wiper control	2-12	Water separator S/N 2001, and above	1-11
		"Weekly" operators/crew PMCS table	2-29
T		Weights	1-13
Table of contents	i	Window locks and controls	2-11
Three movement lever	2-10	Windshield wiper control	2-12
Tilt control lever	2-10	Winter oils	2-33

By Order of the Secretary of the Army

CARL E. VUONO
General, United States Army
Chief of Staff

Official:

WILLIAM J. MEEHAN II
Brigadier General, United States Army
The Adjutant General

Distribution:

To be distributed in accordance with DA Form 12-25 F-R (Block No. 2229) Operator maintenance requirements for Fork Lift, 10,000 LB Capacity, Rough Terrain, Pnuematic Tire, Diesel (Model MHE-236).

RECOMMENDED CHANGES TO EQUIPMENT TECHNICAL PUBLICATIONS



SOMETHING WRONG WITH THIS PUBLICATION?

THEN... JOT DOWN THE DOPE ABOUT IT ON THIS FORM. CAREFULLY TEAR IT OUT. FOLD IT AND DROP IT IN THE MAIL!

FROM: (PRINT YOUR UNIT'S COMPLETE ADDRESS)

OMS #9
P.O. Box 14
Thomasville, TX 99999-0000

DATE SENT

1 Jul 88

PUBLICATION NUMBER

TM 10-3930-643-10

PUBLICATION DATE

PUBLICATION TITLE

Truck, Forklift, DED,
10,000 lb, RT, Model M10A

BE EXACT... PIN-POINT WHERE IT IS

PAGE NO	PARA-GRAPH	FIGURE NO	TABLE NO
3-1	3-2		

IN THIS SPACE TELL WHAT IS WRONG AND WHAT SHOULD BE DONE ABOUT IT:

Change "Control Indicator" to read "Warning Indicator"
Reason: Correct nomenclature.

SAMPLE

PRINTED NAME, GRADE, OR TITLE, AND TELEPHONE NUMBER

SGT John Smith
A1 999-2222

SIGN HERE:

John Smith

FILL IN YOUR
UNIT'S ADDRESS

FOLD BACK

DEPARTMENT OF THE ARMY

OMS #9 (ATTN: SGT SMITH)

P.O. Box 14, Thomasville TX

OFFICIAL BUSINESS

99999-0000

Commander
US Army Tank-Automotive Command
ATTN: AMSTA-MB
Warren, Michigan 48397-5000

SAMPLE

RECOMMENDED CHANGES TO EQUIPMENT TECHNICAL PUBLICATIONS



THEN... JOT DOWN THE DOPE ABOUT IT ON THIS FORM. CAREFULLY TEAR IT OUT. FOLD IT AND DROP IT IN THE MAIL!

SOMETHING WRONG WITH THIS PUBLICATION?

FROM: (PRINT YOUR UNIT'S COMPLETE ADDRESS)

DATE SENT

PUBLICATION NUMBER

TM 10-3930-543-10

PUBLICATION DATE

19 January 1990

PUBLICATION TITLE

Truck, Forklift, DED,
10,000 lb, RT, Model M10A

BE EXACT... PIN-POINT WHERE IT IS

PAGE
NO

PARA-
GRAPH

FIGURE
NO.

TABLE
NO

IN THIS SPACE TELL WHAT IS WRONG
AND WHAT SHOULD BE DONE ABOUT IT:

PRINTED NAME, GRADE OR TITLE, AND TELEPHONE NUMBER

SIGN HERE:

FILL IN YOUR
UNIT'S ADDRESS

FOLD BACK

DEPARTMENT OF THE ARMY

Commander
US Army Tank-Automotive Command
ATTN: AMSTA-MB
Warren, Michigan 48397-5000

FILL IN YOUR
UNIT'S ADDRESS

FOLD BACK

DEPARTMENT OF THE ARMY

Commander
US Army Tank-Automotive Command
ATTN: AMSTA-MB
Warren, Michigan 48397-5000

RECOMMENDED CHANGES TO EQUIPMENT TECHNICAL PUBLICATIONS



SOMETHING WRONG WITH THIS PUBLICATION?

THEN... JOT DOWN THE DOPE ABOUT IT ON THIS FORM. CAREFULLY TEAR IT OUT. FOLD IT AND DROP IT IN THE MAIL!

FROM: (PRINT YOUR UNIT'S COMPLETE ADDRESS)

DATE SENT

PUBLICATION NUMBER

TM 10-3930-643-10

PUBLICATION DATE

19 January 1990

PUBLICATION TITLE

Truck, Forklift, DED,
10,000 lb, RT, Model M10A

BE EXACT... PIN-POINT WHERE IT IS				IN THIS SPACE TELL WHAT IS WRONG AND WHAT SHOULD BE DONE ABOUT IT:
PAGE NO	PARA-GRAPH	FIGURE NO	TABLE NO	

PRINTED NAME, GRADE OR TITLE, AND TELEPHONE NUMBER

SIGN HERE:

FILL IN YOUR
UNIT'S ADDRESS

FOLD BACK

DEPARTMENT OF THE ARMY

Commander
US Army Tank-Automotive Command
ATTN: AMSTA-MB
Warren, Michigan 48397-5000

THE METRIC SYSTEM AND EQUIVALENTS

LINEAR MEASURE

1 Centimeter = 10 Millimeters = 0.01 Meters = 0.3937 Inches
 1 Meter = 100 Centimeters = 1000 Millimeters = 39.37 Inches
 1 Kilometer = 1000 Meters = 0.621 Miles

SQUARE MEASURE

1 Sq Centimeter = 100 Sq Millimeters = 0.155 Sq Inches
 1 Sq Meter = 10,000 Sq Centimeters = 10.76 Sq Feet
 1 Sq Kilometer = 1,000,000 Sq Meters = 0.386 Sq Miles

WEIGHTS

1 Gram = 0.001 Kilograms = 1000 Milligrams 0.035 Ounces
 1 Kilogram = 1000 Grams = 2.2 Lb
 1 Metric Ton = 1000 Kilograms = 1 Megagram = 1.1 Short Tons

CUBIC MEASURE

1 Cu Centimeter = 1000 Cu Millimeters = 0,06 Cu Inches
 1 Cu Meter = 1,000,000 Cu Centimeters = 35.31 Cu Feet

LIQUID MEASURE

1 Milliter = 0.001 Liters = 0.0338 Fluid Ounces
 1 Liter = 1000 Milliliters = 33.82 Fluid Ounces

TEMPERATURE

$5/9 (^{\circ}\text{F} - 32) = ^{\circ}\text{C}$
 212° Fahrenheit is equivalent to 100° Celsius
 90° Fahrenheit is equivalent to 32.2° Celsius
 32° Fahrenheit is equivalent to 0° Celsius
 $9/5 \text{ } ^{\circ}\text{C} + 32 = ^{\circ}\text{F}$

APPROXIMATE CONVERSION FACTORS

<u>TO CHANGE</u>	<u>TO</u>	<u>MULTIPLY BY</u>
Inches	Centimeters	2.540
Feet	Meters	0.305
Yards	Meters	0.914
Miles	Kilometers	1.609
Square Inches	Square Centimeters	6.451
Square Feet	Square Meters	0.093
Square Yards	Square Meters	0.836
Square Miles	Square Kilometers	2.590
Acres	Square Hectometers	0.405
Cubic Feet	Cubic Meters	0.028
Cubic Yards	Cubic Meters	0.765
Fluid Ounces	Milliliters	29.573
Pints	Liters	0.473
Quarts	Liters	0.946
Gallons	Liters	3.785
Ounces	Grams	28.349
Pounds	Kilograms	0.454
Short Tons	Metric Tons	0.907
Pound-Feet	Newton-Meters	1.356
Pounds per Square Inch	Kilopascals	6.895
Miles per Gallon	Kilometers per Liter	0.425
Miles per Hour	Kilometers per Hour	1.609

<u>TO CHANGE</u>	<u>TO</u>	<u>MULTIPLY BY</u>
Centimeters	Inches	0.394
Meters	Feet	3.280
Meters	Yards	1.094
Kilometers	Miles	0.621
Square Centimeters	Square Inches	0.155
Square Meters	Square Feet	10.764
Square Meters	Square Yards	1.196
Square Kilometers	Square Miles	0.386
Square Hectometers	Acres	2.471
Cubic Meters	Cubic Feet	35.315
Cubic Meters	Cubic Yards	1.308
Milliliters	Fluid Ounces	0.034
Liters	Pints	2.113
Liters	Quarts	1.057
Liters	Gallons	0.264
Grams	Ounces	0.035
Kilograms	Pounds	2.205
Metric Tons	Short Tons	1.102
Newton-Meters	Pound-Feet	0.738
Kilopascals	Pounds per Square Inch	0.145
Kilometers per Liter	Miles per Gallon	2.354
Kilometers per Hour	Miles per Hour	0.621

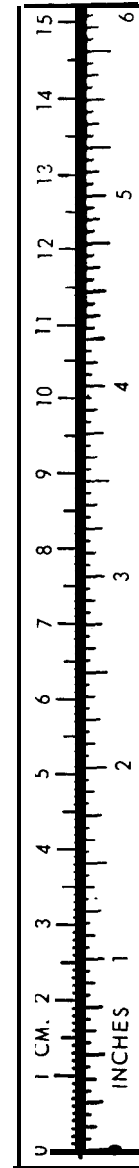

TA089991

